



canmetals.com

PRESENTATION

COMPANY PROFILE

Can Otomotiv, mainly operating in automotive industry with their 40+ years of experience, one of the lead firms of Turkiye. They offer solutions to automotive, food, defence, aviation, cosmetics, transportation, health, construction and many other industries as **Can Metals** with advanced technologies like laser cutting, CNC milling, bending and plastic injection.

By investing towards production infrastructure they aim to meet both their manufacturing requirements and to achieve a sustainable commercial activity.

Nowadays, based on the engineering and technological competences we have;

By using the project management management methods that are worldwide accepted, we aim to continue successful **PROJECTS** in all fields we can appeal to,

In projects that we took part, by using **ENGINEERING** applications; research-development, industrial design and performance of test activities,

In **PRODUCTION** field which is a result of engineering activities; we aim to make fast, quality, cost effective, organized, efficient and turnkey manufacturing towards all kind of industry field.



CAN
METALS



OUR VISION

Becoming a institutional firm
in our fields by using
advanced engineering
and production technologies

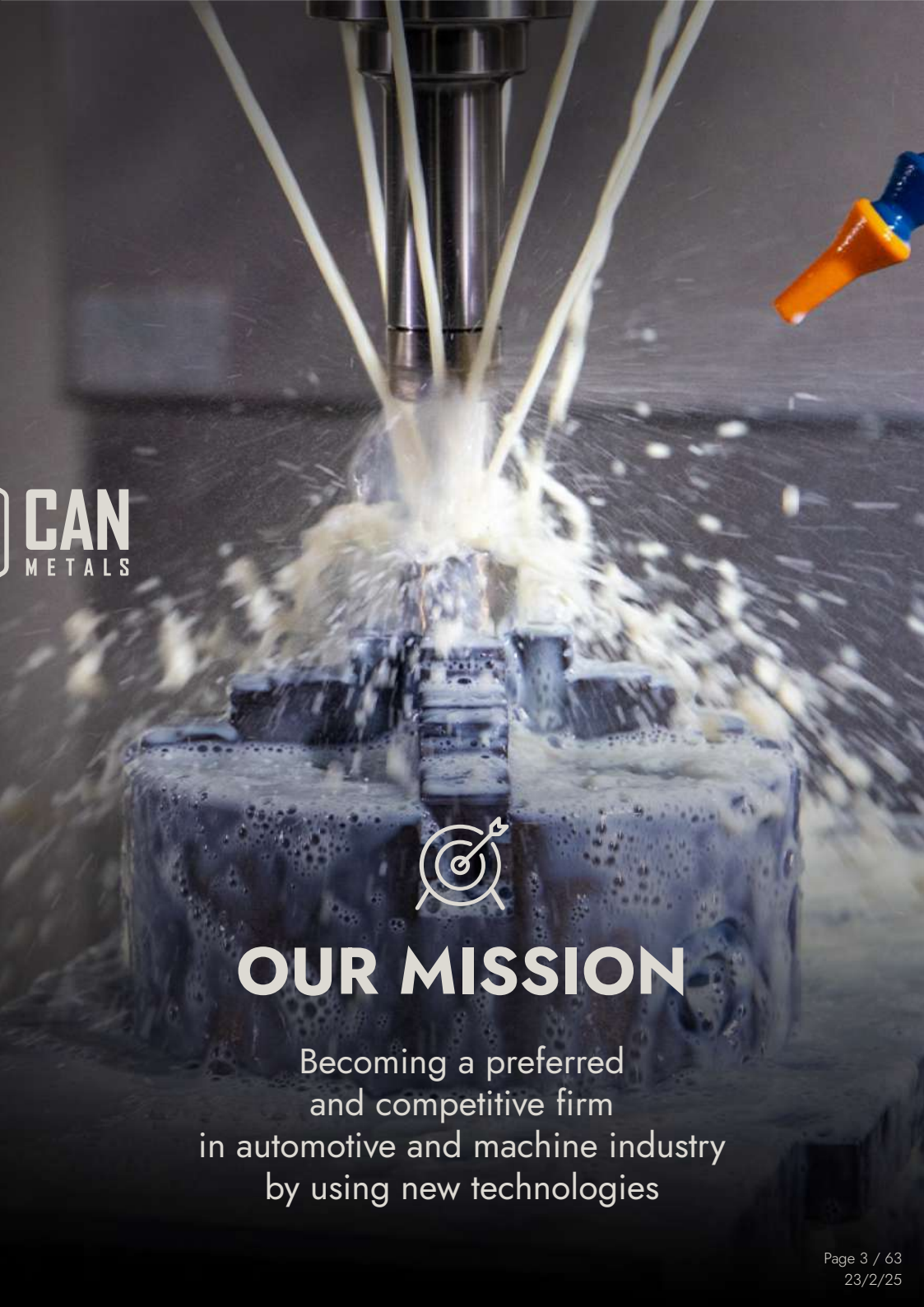

OUR MISSION

Becoming a preferred
and competitive firm
in automotive and machine industry
by using new technologies



In the integrated factory that is built to **10.000 mt** field at Tekirdag/Cerkezko
Velikoy Organized Industry Region; in their own structure, they carry out
their production process at latest tech metal processing and
production lines like 3D scanning & design, planning,
CNC milling at mold workshop, plastic injection molding,
laser cutting bending, welding.

Following the developments in sector with
stable growth, Can Otomotiv doesn't miss
the updated trends of market, brings
their investments to life regularly.

95+
expert staff.

In transportation vehicle equipment
production that keeps growing every year

150.000
per year.



40 YEARS OF EXPERIENCE

Certified LPG Tanks
Vehicle Skid Plate
Pickup Roll Bars
Vehicle Protection Bars
Military Protection Bars

Factory

10.000 m² TOTAL AREA

8.000 m² CLOSED AREA

1.500 m² OFFICE

Germany WAREHOUSE

1.200 m² TOTAL AREA

200 m² OFFICE

USA WAREHOUSE

600 m² TOTAL AREA

50 m² OFFICE

"We produce our own energy."



EXPORTS MORE THAN 40 COUNTRIES

85% EXPORT

15% DOMESTIC MARKET

- | | |
|------------|----------------------|
| Algeria | Czech Republic |
| Australia | Malta |
| Austria | Moldova |
| Azerbaijan | Morocco |
| Belarus | Norway |
| Bulgaria | Panama |
| Canada | Poland |
| Denmark | Romania |
| Egypt | Serbia |
| France | Slovakia |
| Georgia | Spain |
| Germany | Sweden |
| Greece | Taiwan |
| Hungary | Thailand |
| Iceland | Netherlands |
| Ireland | Tunisia |
| Israel | Turkey |
| Italy | Ukraine |
| Jordan | United Arab Emirates |
| Kazakhstan | United Kingdom |
| Latvia | United States |
| Libya | Uzbekistan |
| Lithuania | |

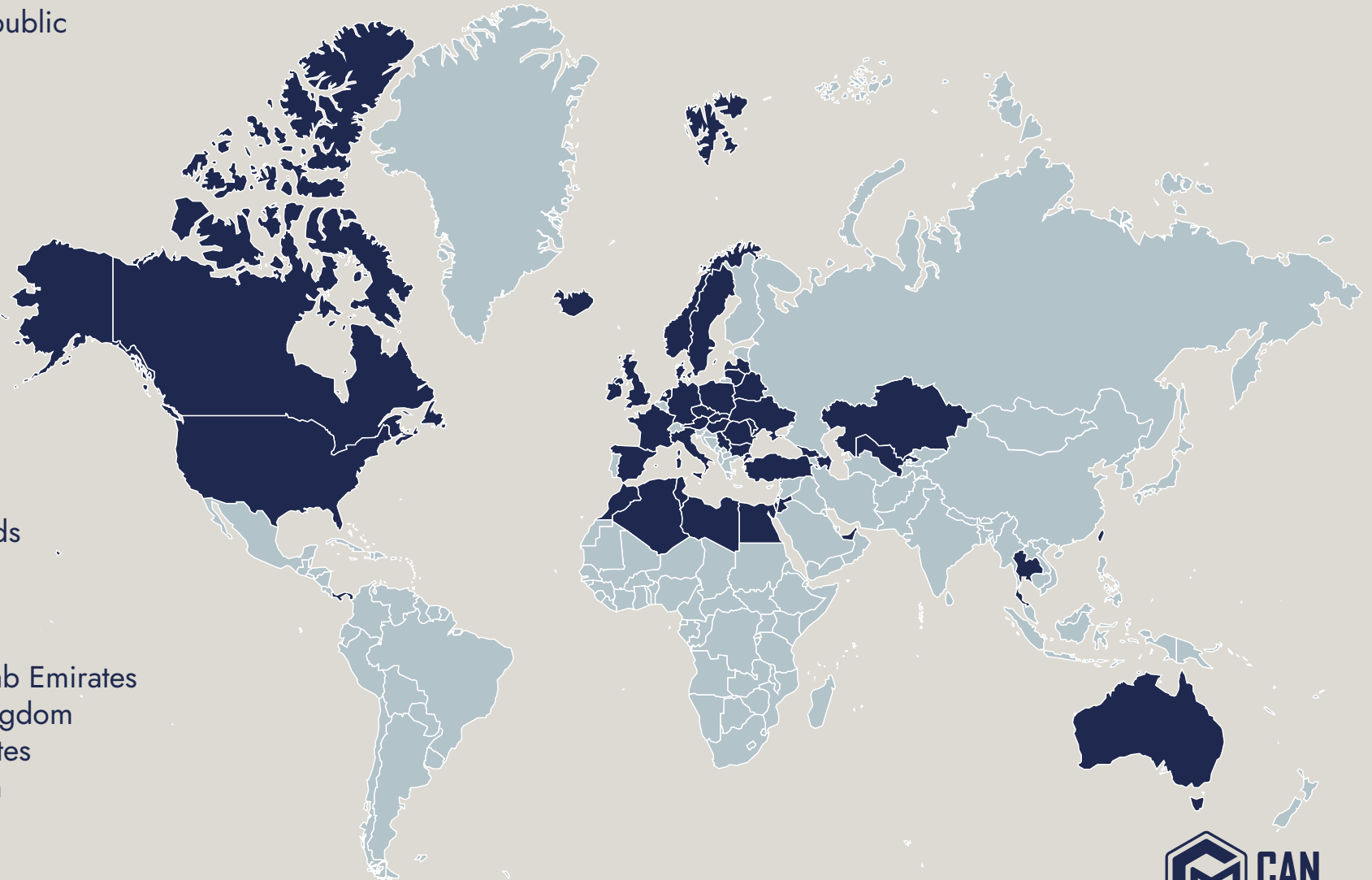

Our firm that is a lead in automotive industry with their production experience,

It continues the growth by it's current installed capacity and advanced machine modernization investment with advanced technology.

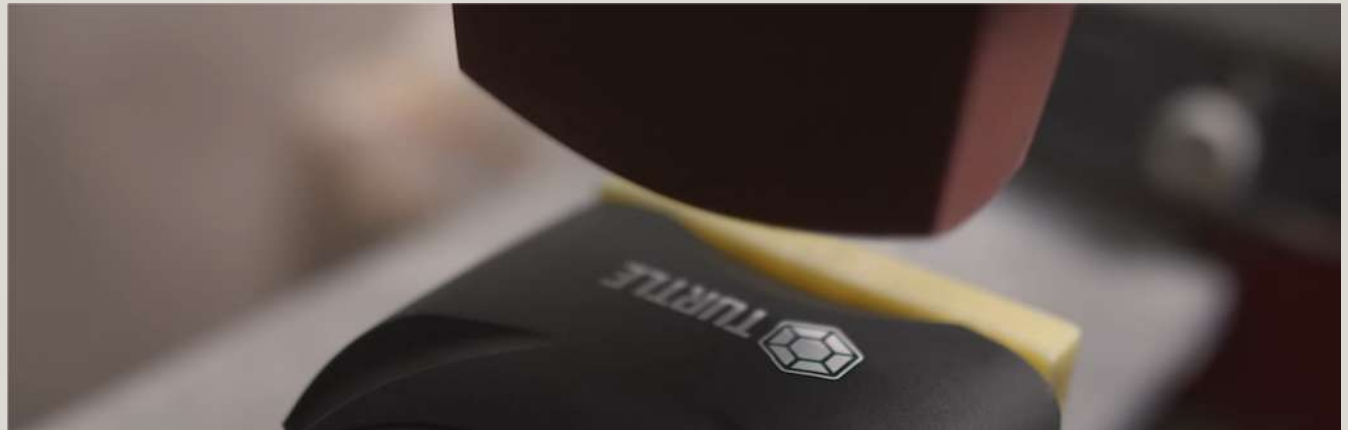

Factory Production

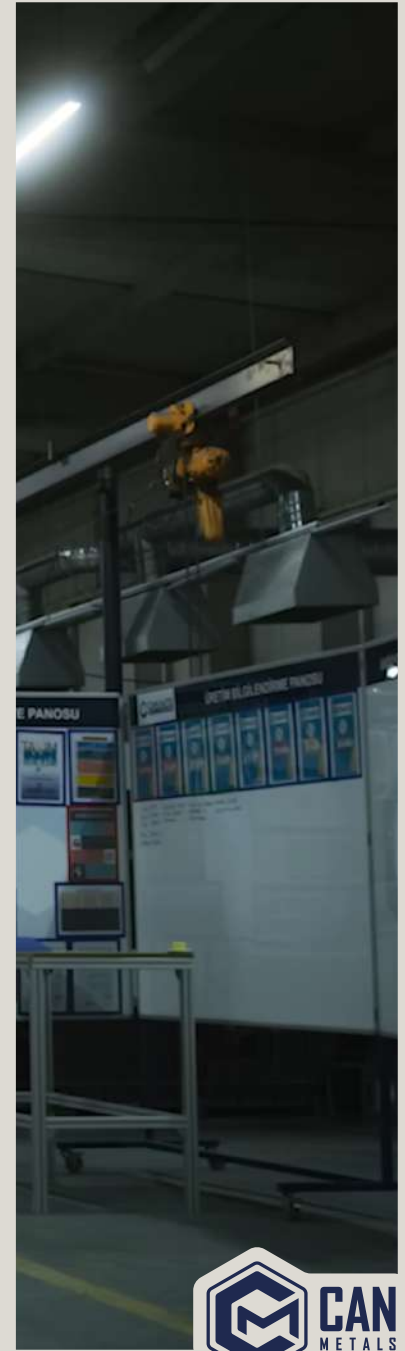

WE HAVE A GREAT TEAM!



EFFICIENT, FLEXIBLE, PRODUCTIVE WORKING ENVIRONMENT



WE HAVE A STRONG AND EDUCATED TEAM!

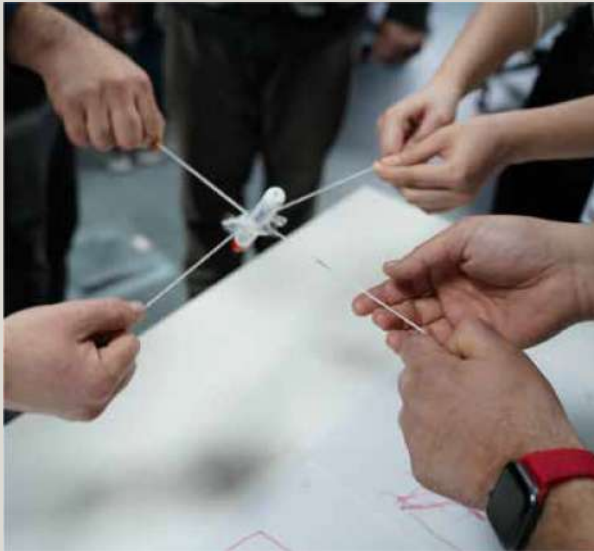

SOME OF THESE TRAININGS

Marketing and Sales Management
Sales Communication and Body Language
Time & Team & Meeting Management
Seven Habits Of Highly Effective People
5S Method · Kaizen
Value Stream Map
SMED · Poka-Yoke
Total Quality Management
Quality Improvement and Problem Solving
Basic Occupational Health and Safety
General Documentation
ISO 9001 Knowledge Based Training
R&D · Innovation · Agile · Scum
Corrective and Preventive Action
Process Training
Marketing Techniques
Customer Relationship Management
Supply Chain Management
Human Resource Management
ERP - Enterprise Resource Planning
QMS Related Formats



ROOF BOX



ROOF RACK CROSS BARS



ROOF RAILS



BIKE RACK



OUR PRODUCT RANGE



SKI RACKS



ROOF BASKET



SIDE STEPS



CAMPING

OUR QUALITY POLICY & SUPPLIER CRITERIA



BASIC PRINCIPLES OF OUR QUALITY POLICY

Customer Focused: Offering compatible solutions by understanding the needs

Quality Management System: Increasing the activity and efficiency on the process

Active Management: Teamwork, determining the authority & responsibilities of employees

Continuous Advancement & Innovation: Creating new ideas with technological advancements

Work Health and Security: Offering a safe working place for our employees

Environment Awareness: Working on bringing the the environmental effects to minimum

Compatible With Standards: Working compatible with national & international standards

Risk Management: Taking preventions by determining the potential risks

Transparency and Partnership: Establishing an open and transparent communication with our partners for cooperating



OUR SUPPLIER CRITERIA

Product Quality: Products and services must fit to ISO-9001 quality standards.

Process Quality: Production processes must be constantly reviewed and improved.

Quality Control Systems: Production must be carried out with an effective quality system.

On-Time Delivery: Orders must be delivered completely on the specified date.

Logistics: Suitable logistics solutions must be provided for safe & damage-free delivery.

Inventory Management: Stock levels must be maintained to respond quickly to demands.

Experience and Expertise: Must have sufficient experience in the metalworking sector.

Social Responsibility: Must respect employee rights and comply with OHS issues.

Privacy: Must protect trade secrets and comply with confidentiality agreements.

CERTIFICATION, TRADEMARK REGISTRATION AND PATENTS



CERTIFICATION, TRADEMARK REGISTRATION AND PATENTS

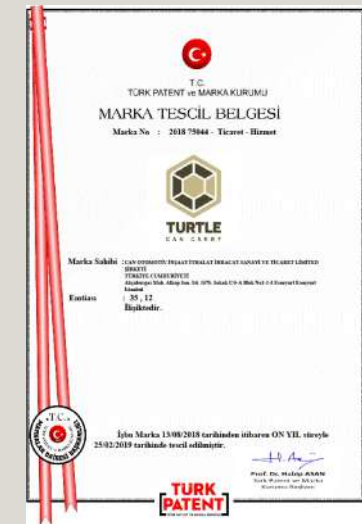
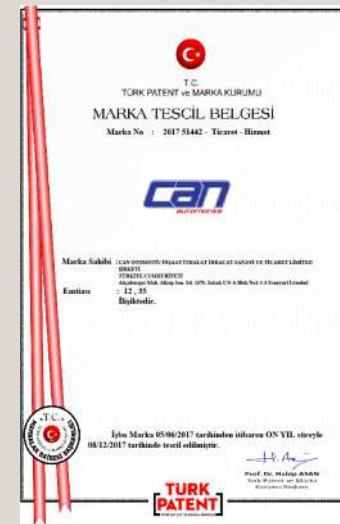

OUR SHORT-TERM STRATEGIC GOALS



As Can Metals, we are taking an important step towards raising our quality standards to the highest level by focusing on continuous development and customer satisfaction.

Following our investment in a high-tech 3D measuring and reporting device (CMM), which we plan to complete in a short time, we will begin work on implementing the AS/EN 9100 quality and risk management standard, which is critical for the aviation, space and defense industries.

Quality
Reliability Move

3D Measurement
AS/EN 9100 Standard

AS/EN 9100, an indispensable standard for companies operating in critical sectors such as aviation, space and defense, requires the implementation and continuous improvement of quality management systems at the highest level. With this strategic move, we will increase our product and service quality and increase our competitive power in the sector. Our goal is to create a quality infrastructure that is suitable not only for today's needs but also for the needs of the future.

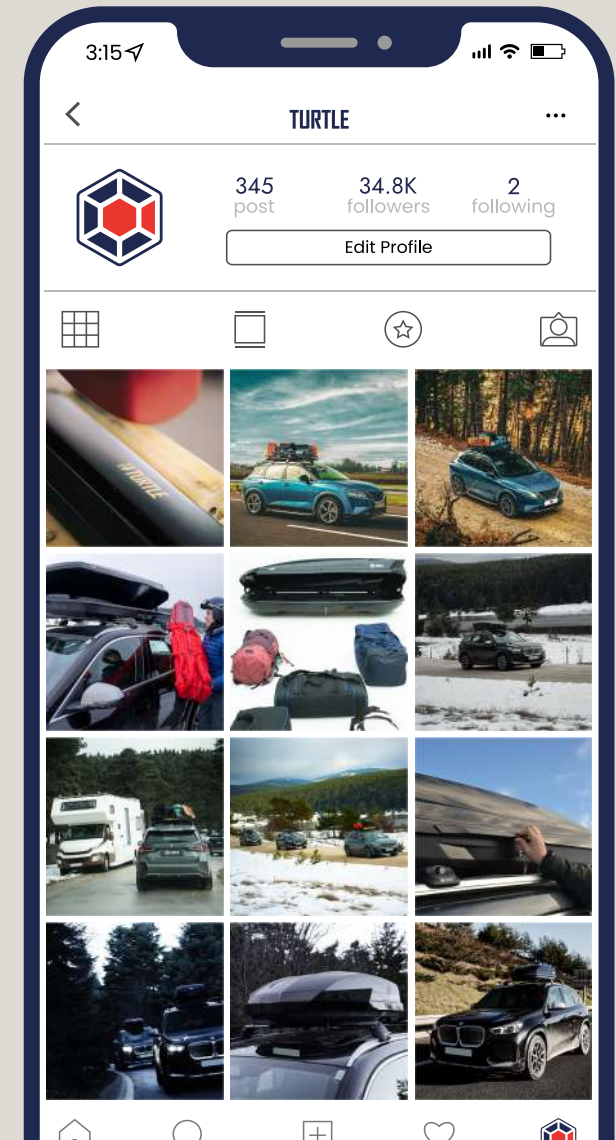
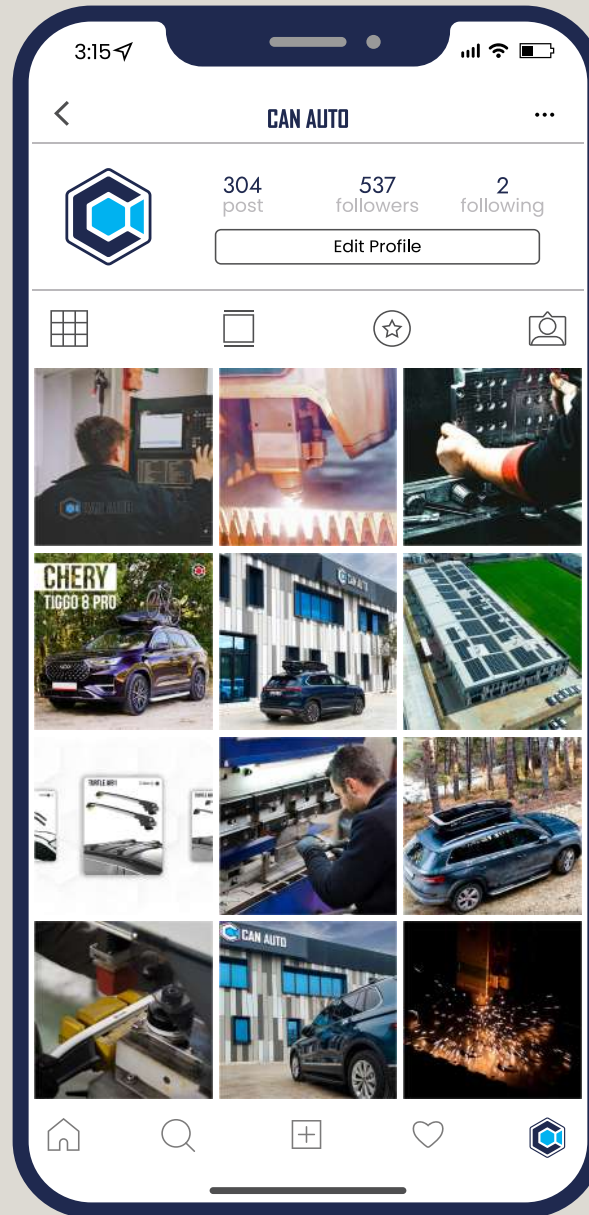
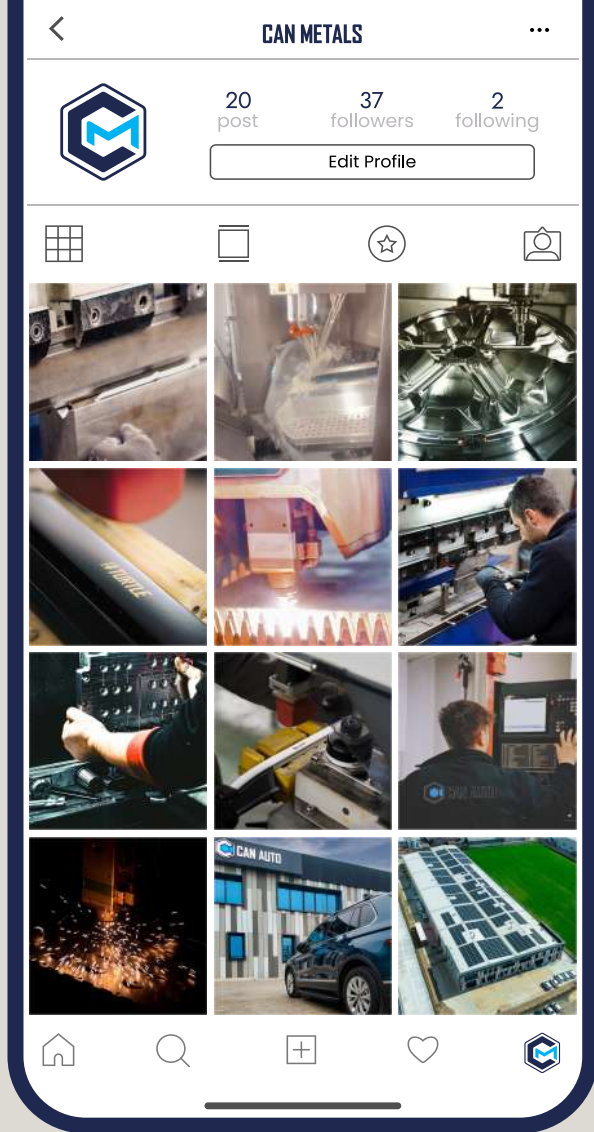

Social Media

At the same time, our products and services can be accessed through online channels.

END-TO-END DIGITALIZATION



We make all processes controllable and measurable with end-to-end digitalization.

“WE MANAGE ALL OF OUR PROCESSES DIGITALLY.”

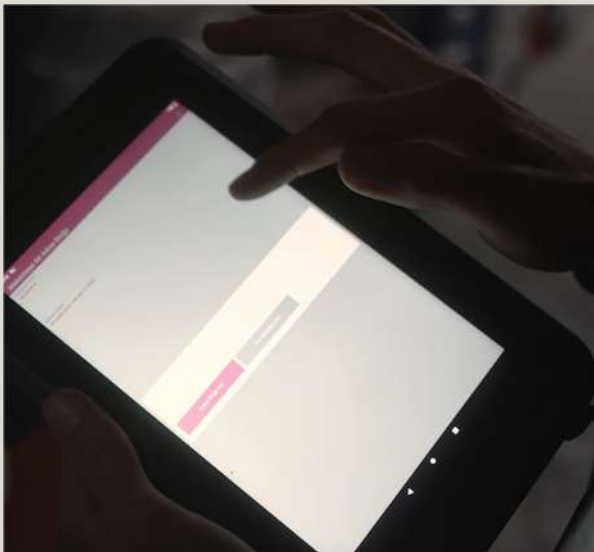

In this way, we completed the first six months of 2022 with a 30% increase in productivity and a 75% increase in delivery speed compared to the first 6 months of previous years, and we reduced the defect rate from 4 per thousand to 1.5 per thousand.



FAIRS WE ATTENDED

AUTOMECHANIKA
ISTANBUL - MAY 2022
FRANKFURT - SEPTEMBER 2022

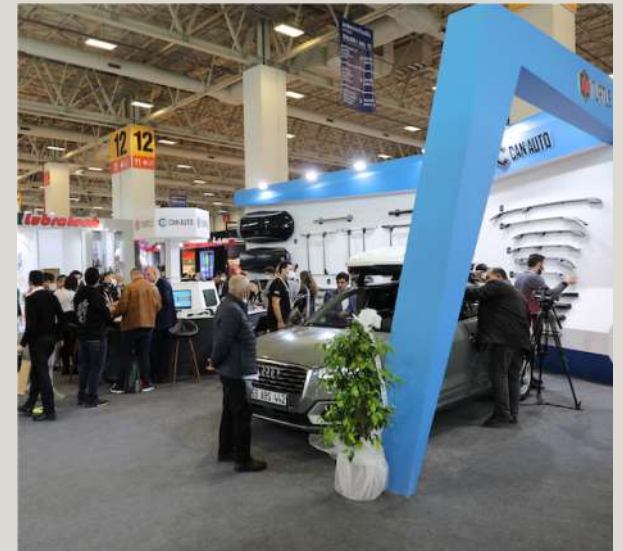

MOLD STORAGE AREA

Plastic Injection | Cutting and Plastering | Bending | Drilling

PLASTIC INJECTION PRODUCTION STATIONS

Plastic Injection | Raw Material Mixer | Crusher



REFERENCES AND SOLUTION PARTNERS



TECHNOLOGY AND SOFTWARE



3D Design and Simulation

We design and simulate with powerful software such as SolidWorks and Siemens NX.

1. We Shape the Future with the Power of Three-Dimensional Design



3D Printing and Prototyping

In addition to our current machining, we also use different prototyping technologies.



2. Your Ideas Come to Life

Graphic Design & Content Production

We produce original visual content that reflects the product character for a better customer experience.

3. The Power of Visual Communication



4. Precise and Accurate Production Processes

Production Technologies

In addition to high-precision production, we develop products with reverse engineering applications.

Measurement and Control

With our precision measurement devices, we offer 3D scanning and modeling solutions in accordance with standards.

5. We Measure Quality



CNC Milling & EDM



Laser Cutting & Bending



Plastic Injection Molding



Vertical Machining



OUR MAIN SERVICES



Development & Design



CNC Bending & Welding



Quality Control

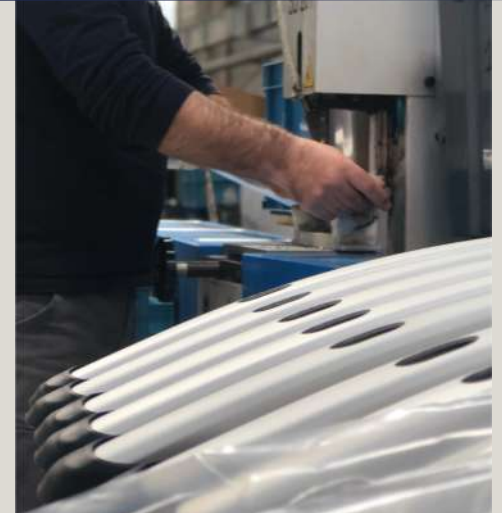

Assembly & Packaging

Plastic Injection



Thermoforming Vacuum



IML Thin Walled Injection



MOLD DESIGN & MANUFACTURING



Extrusion & PET Blowing



Sheet Metal Cutting & Plastering

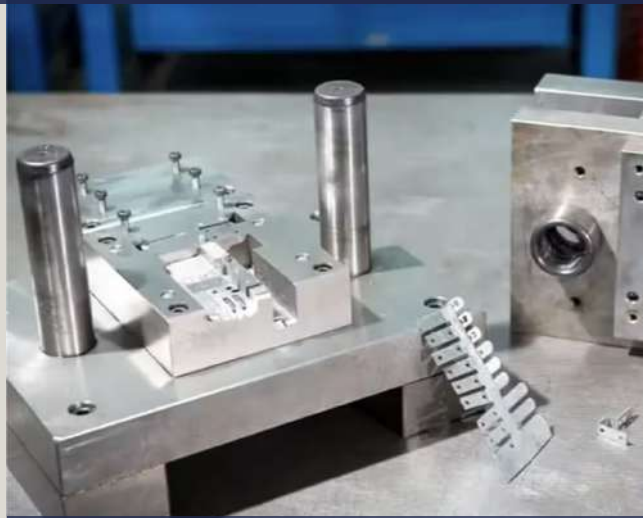

Casting (Steel & Aluminum)

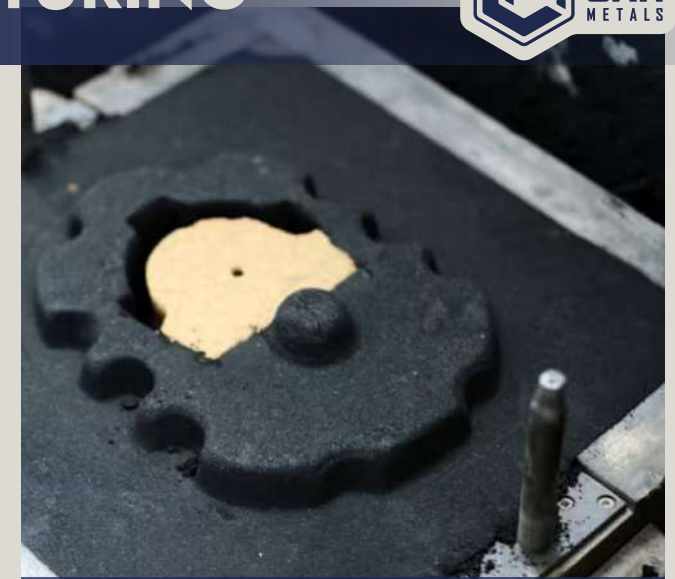

MOLD AND APPLICATION EXAMPLES

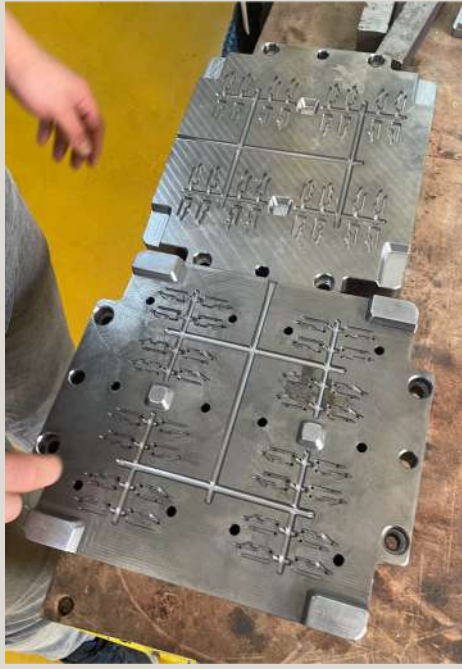
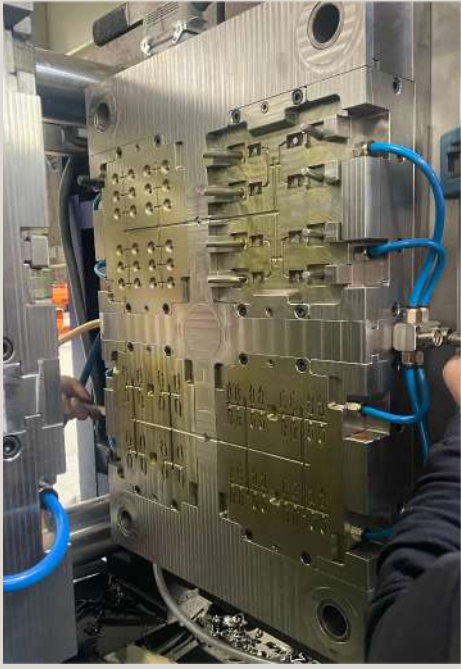

MOLD AND APPLICATION EXAMPLES

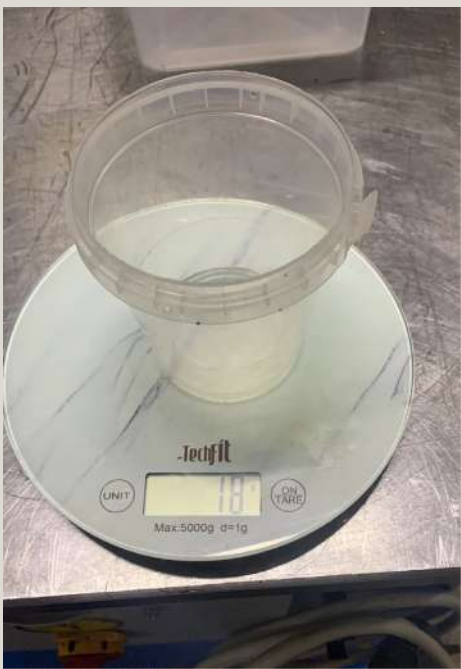
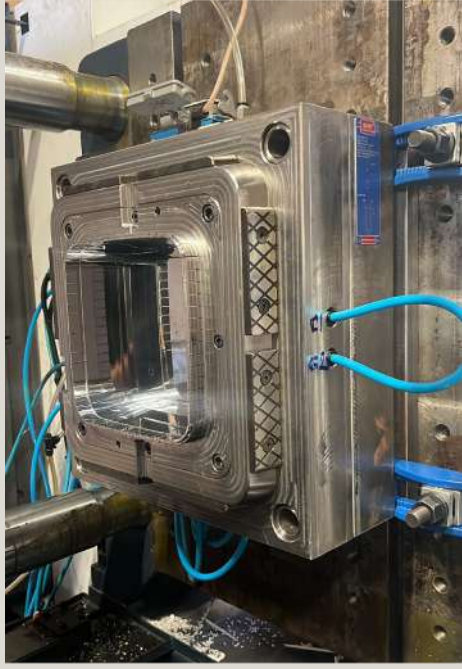
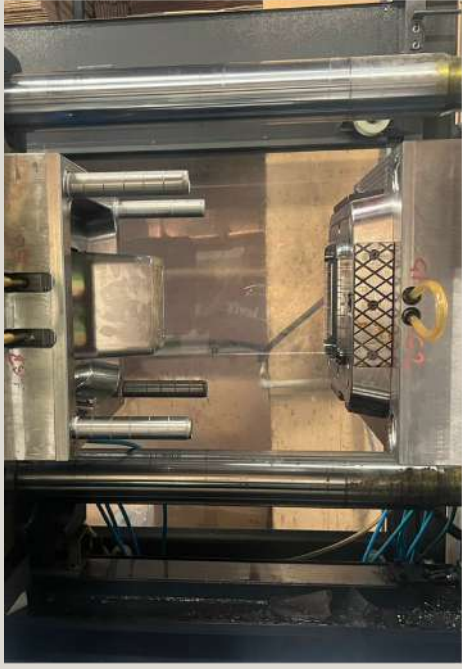

MOLD AND APPLICATION EXAMPLES





ICE CREAM CONE MODEL DESIGN AND MOLD MANUFACTURING

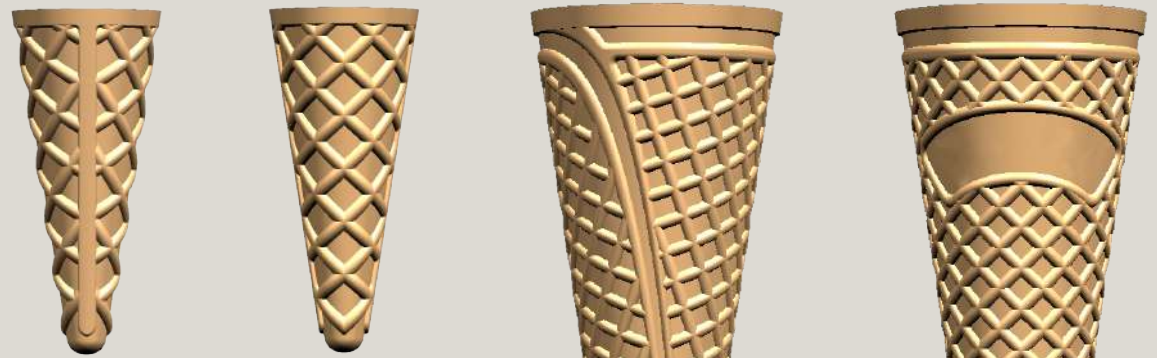
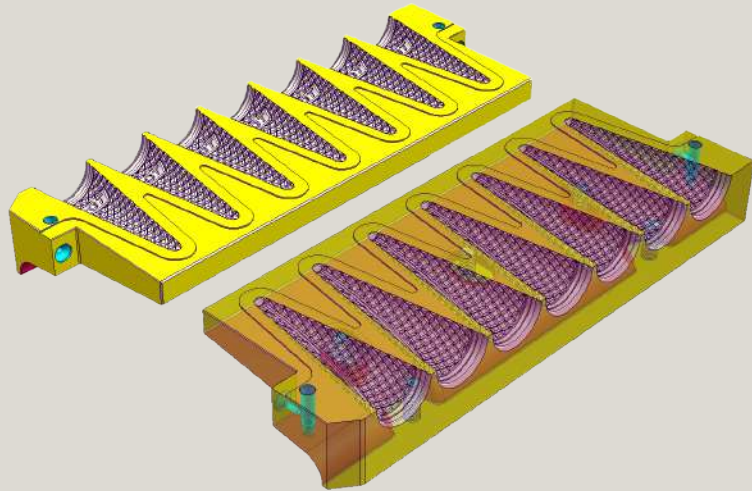

FROM DREAM
TO REALITY

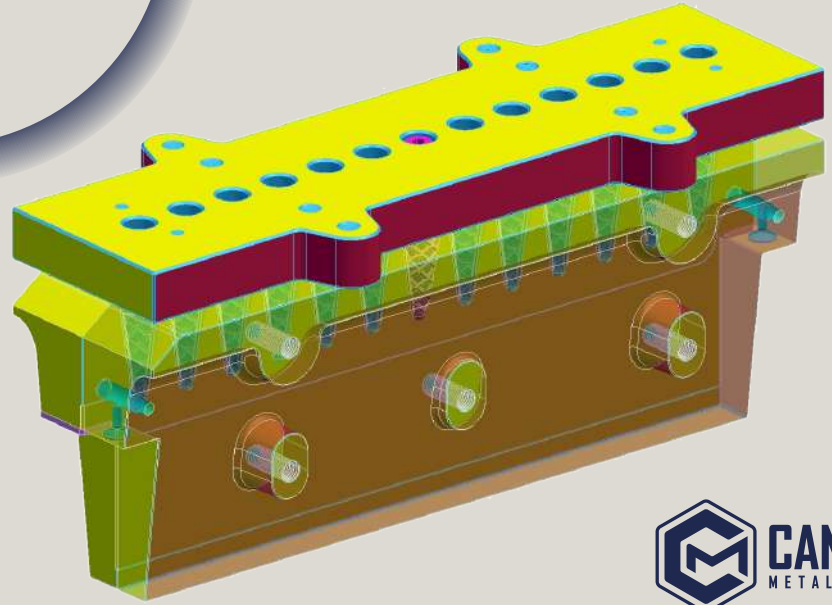
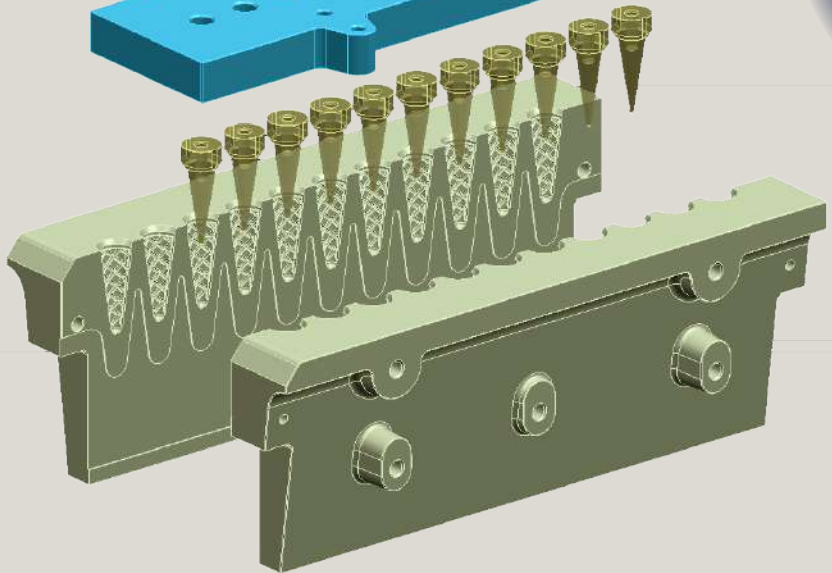
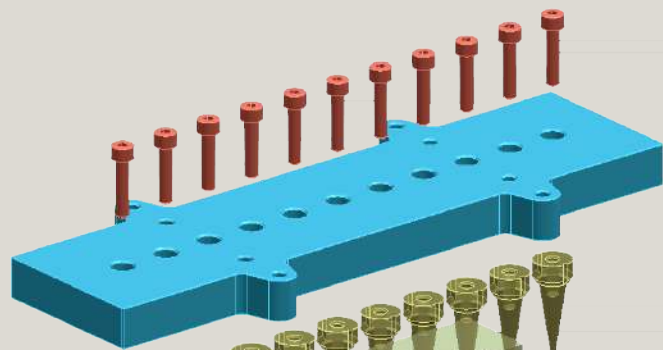

ICE CREAM CONE MODEL DESIGN AND MOLD MANUFACTURING

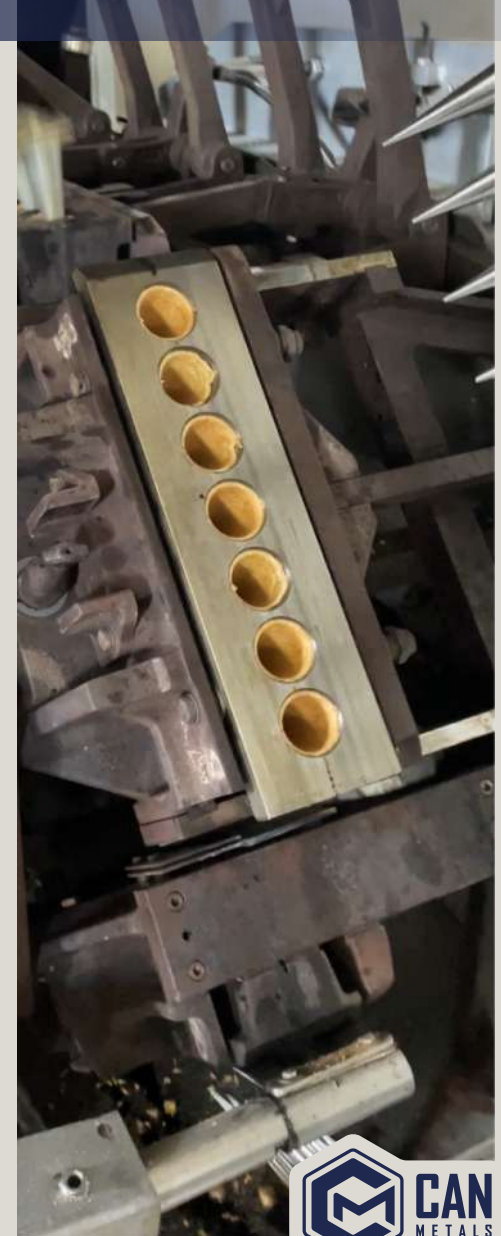

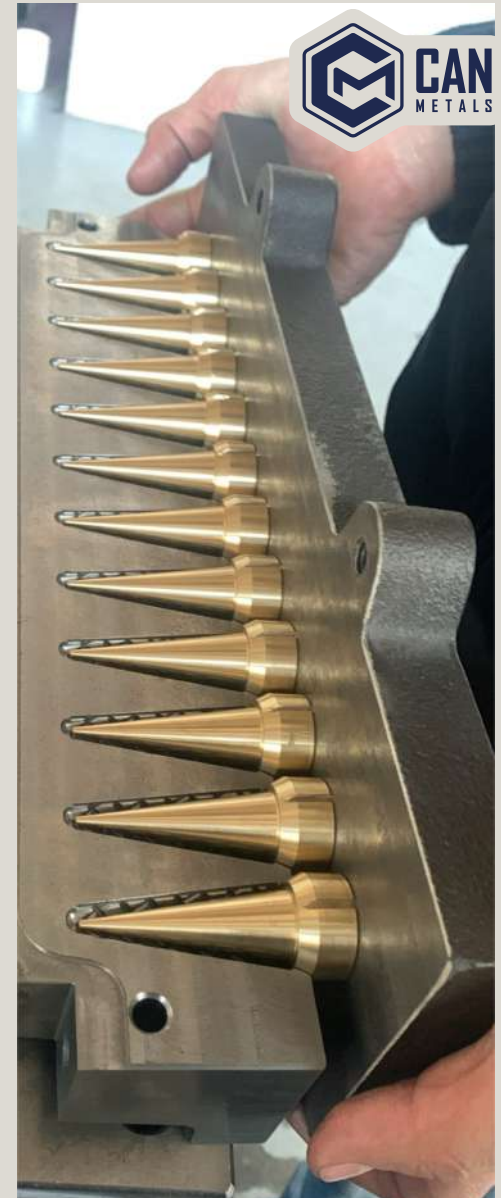
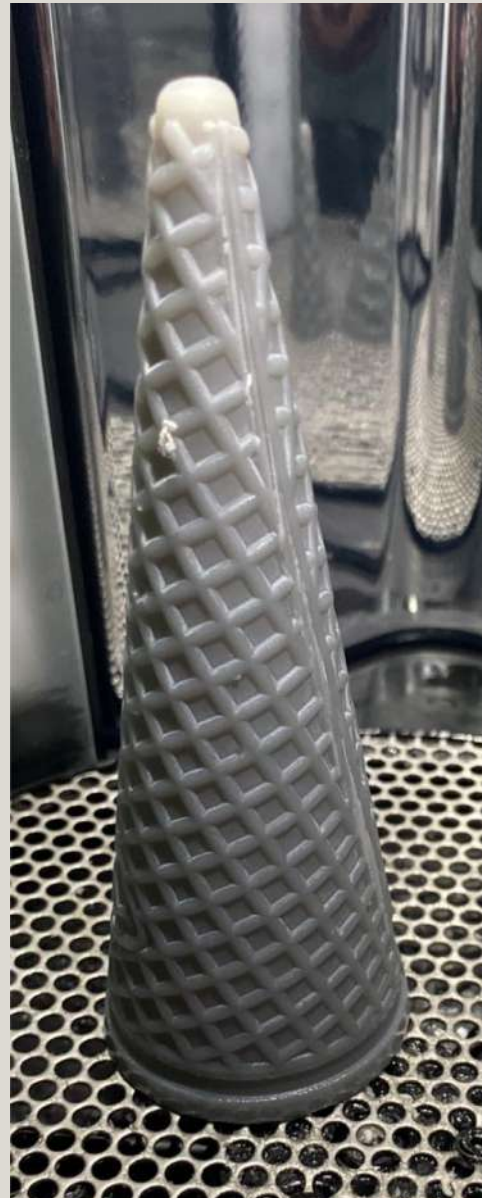

ICE CREAM CONE MODEL DESIGN AND MOLD MANUFACTURING



ICE CREAM CONE MODEL DESIGN AND MOLD MANUFACTURING

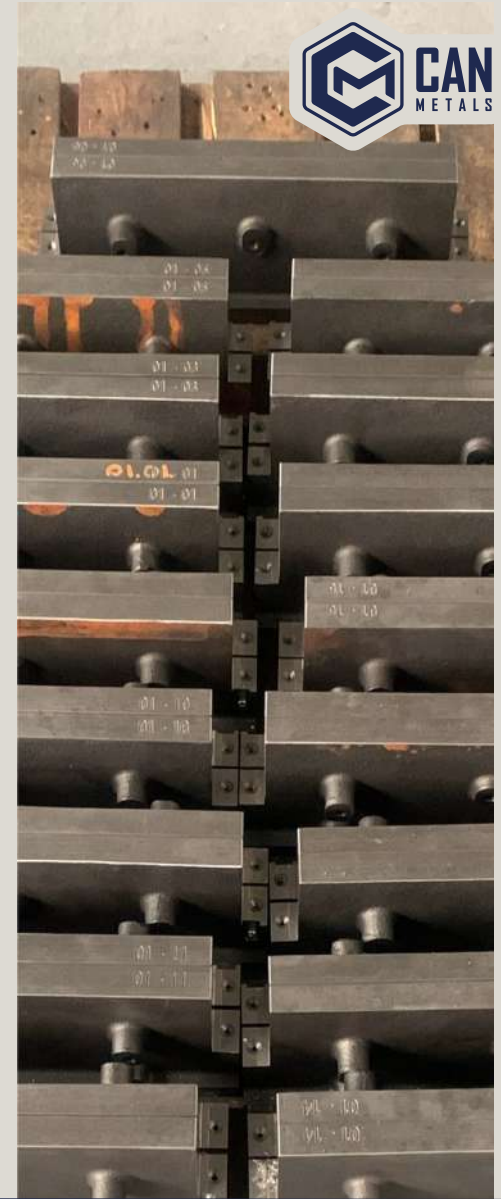

ICE CREAM CONE MODEL DESIGN AND MOLD MANUFACTURING

MERCEDES-BENZ **VIP CONSOLE** DEVELOPMENT

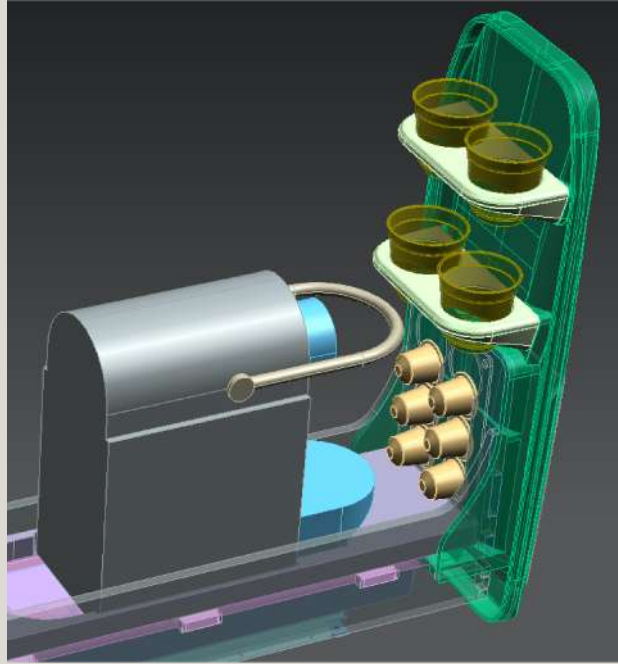

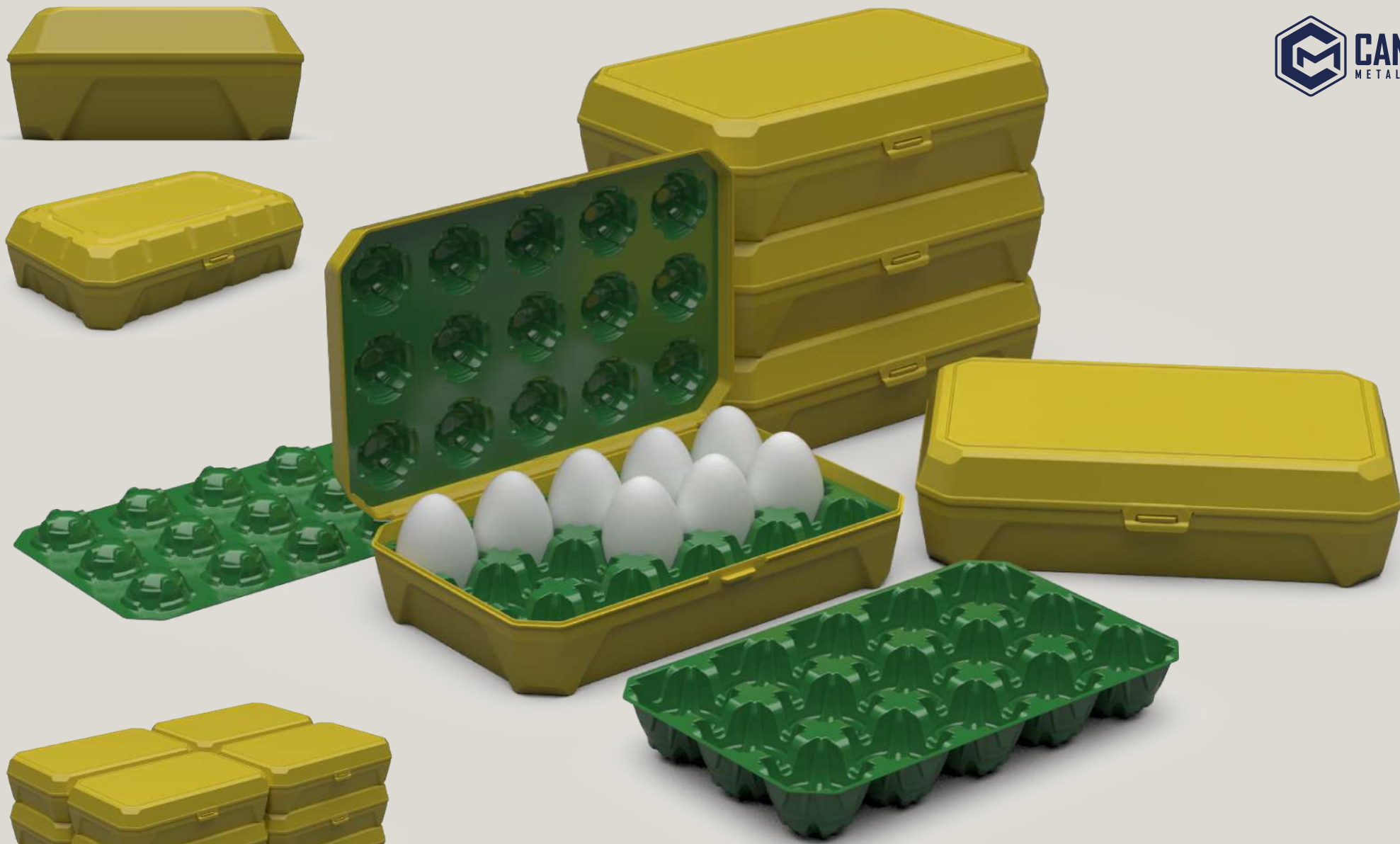

EGG PACKAGING DESIGN AND MOLD MANUFACTURING



EGG PACKAGING DESIGN AND MOLD MANUFACTURING

PLASTIC PART DESIGN AND MODELLING

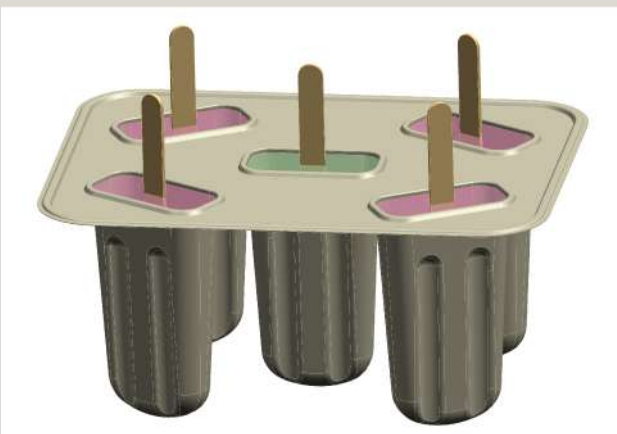
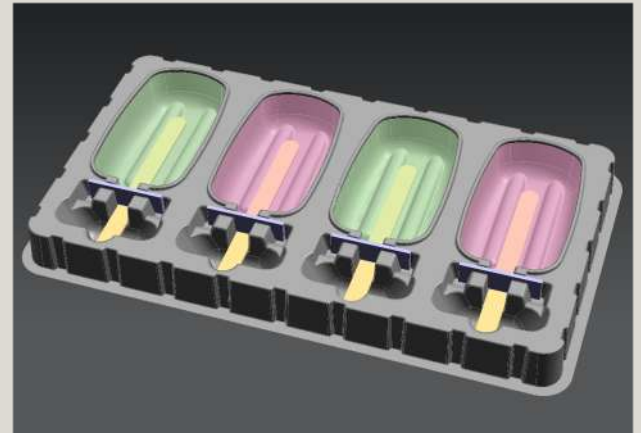
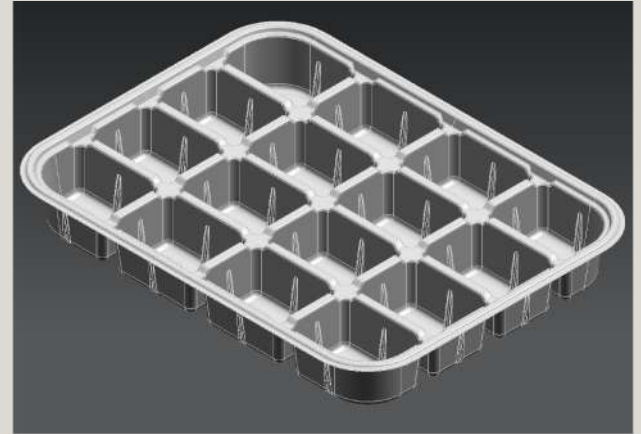

PLASTIC PART DESIGN AND MODELLING

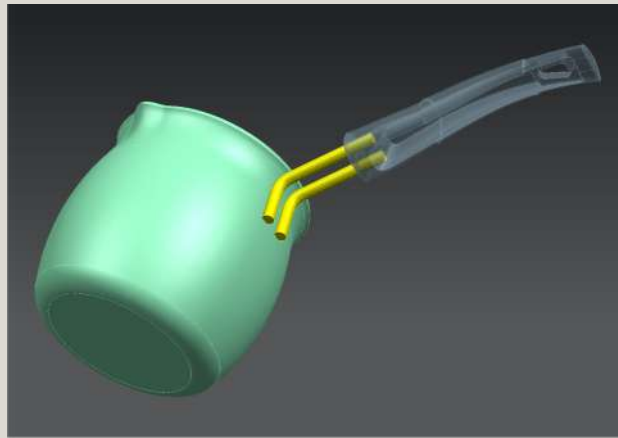
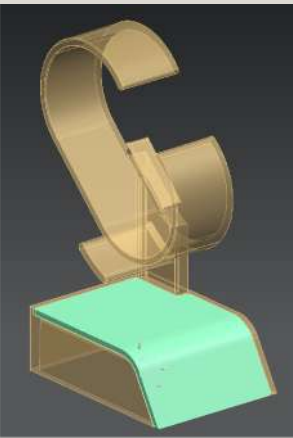
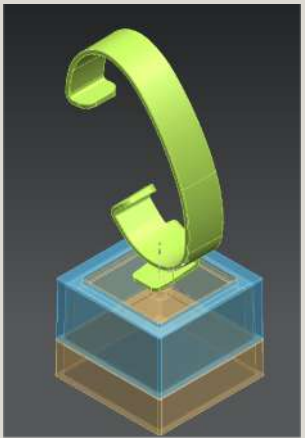
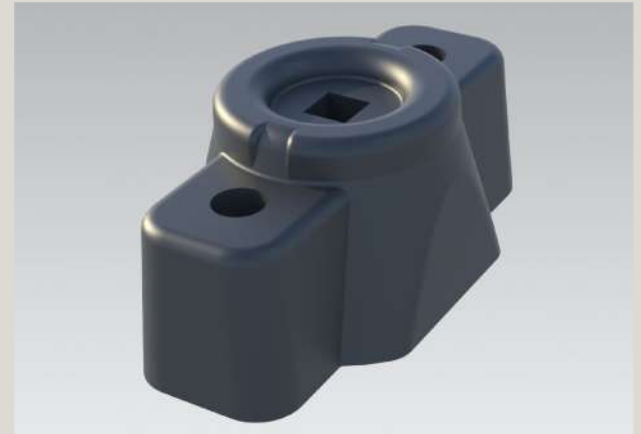
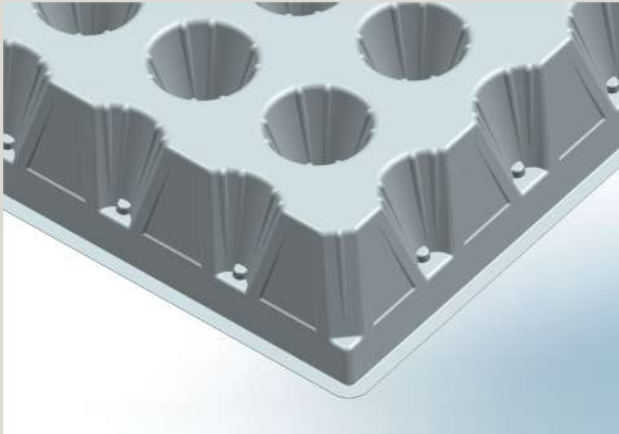
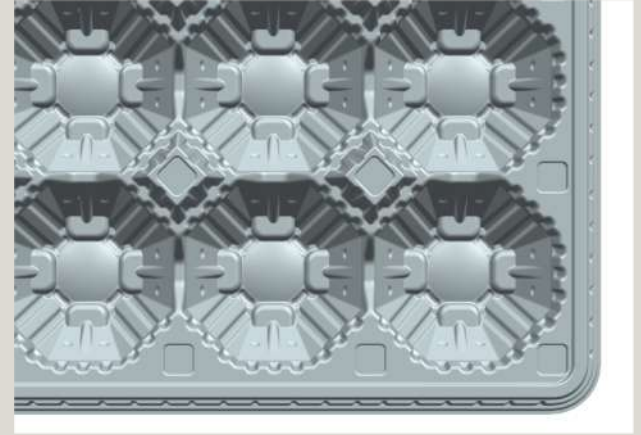
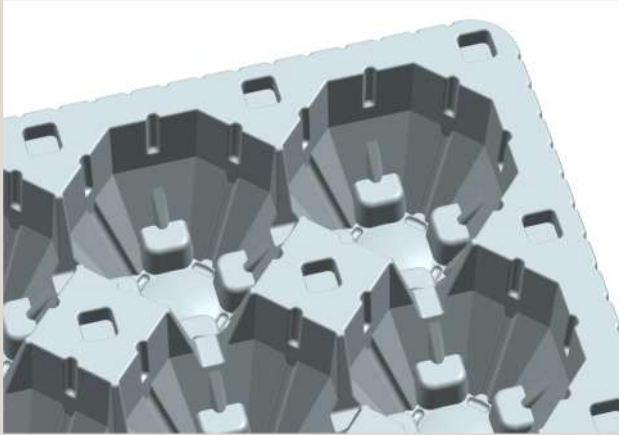

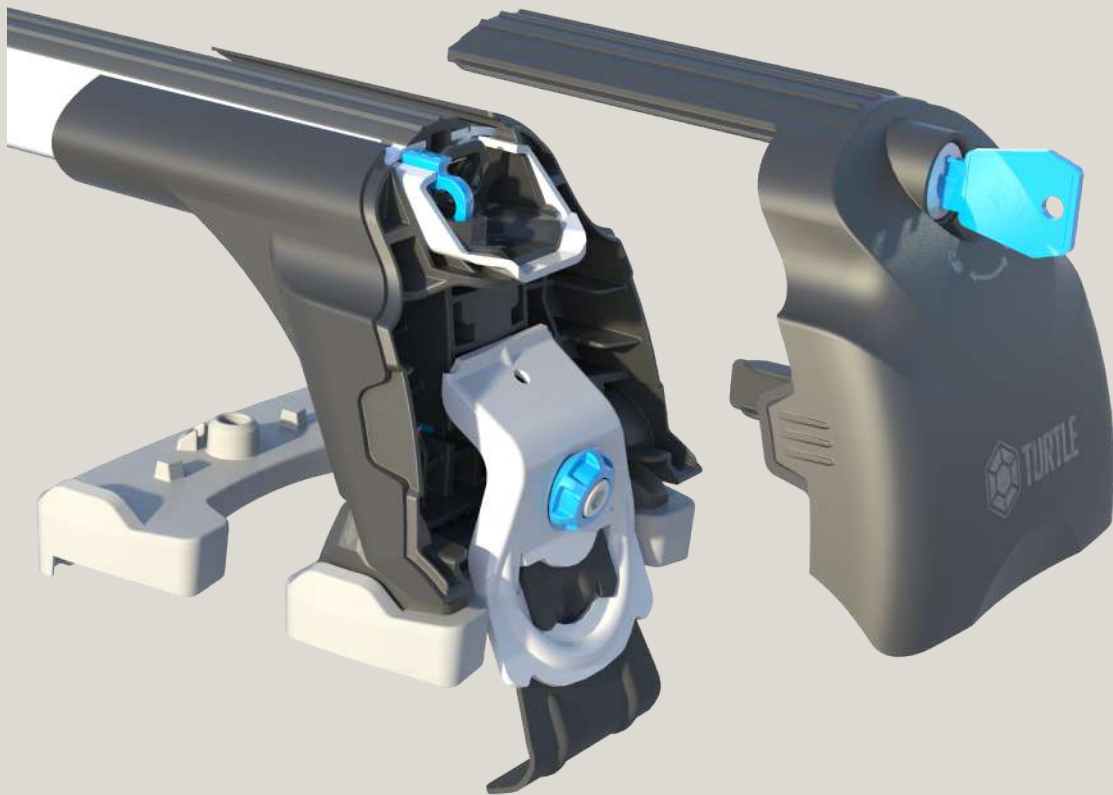

ROOF RACK
CROSS BARS
PRODUCT
DEVELOPMENT



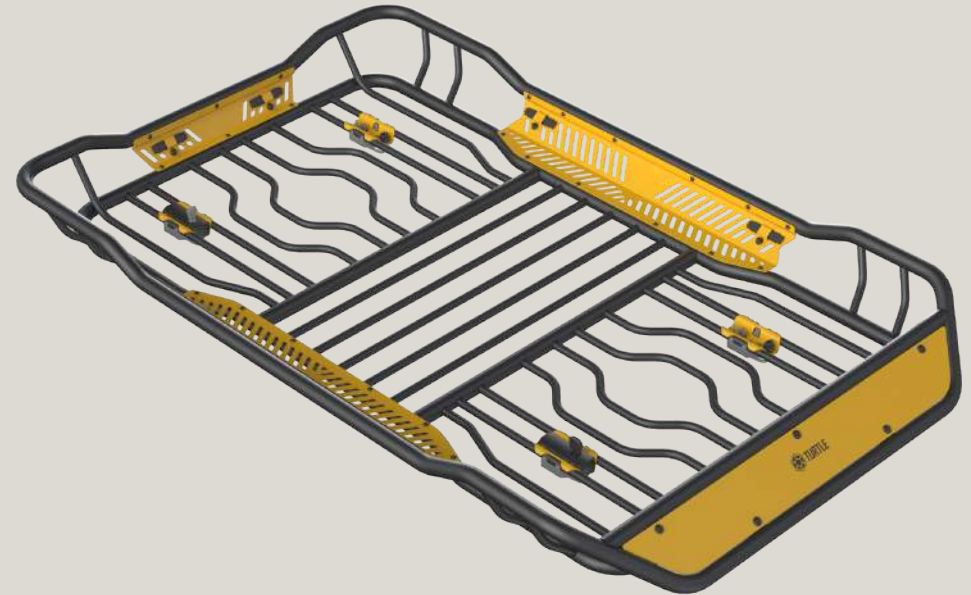
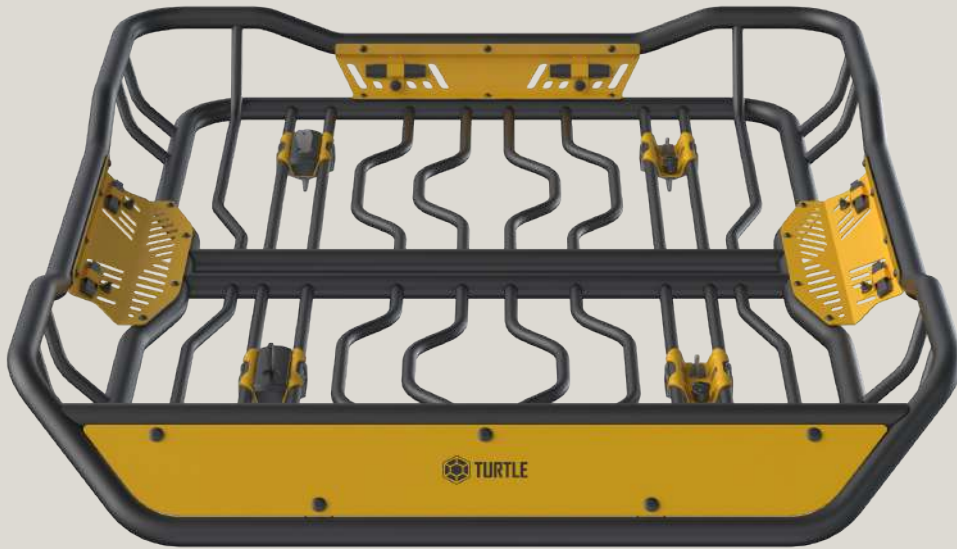

ROOF BASKET PRODUCT DEVELOPMENT

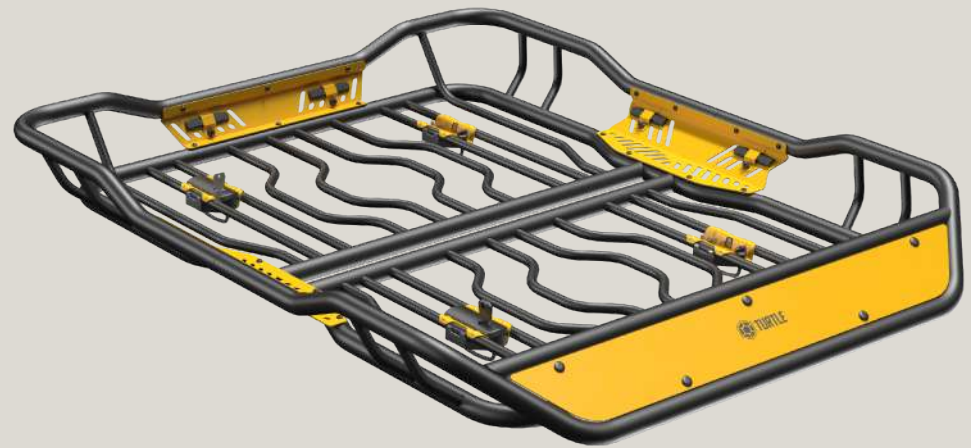



BIKE RACK PRODUCT DEVELOPMENT





ROOF PLATFORM PRODUCT DEVELOPMENT

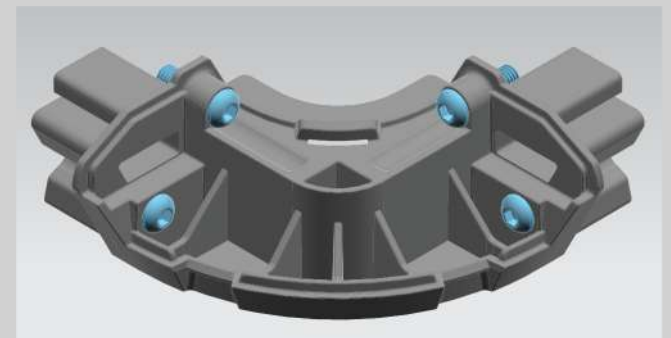
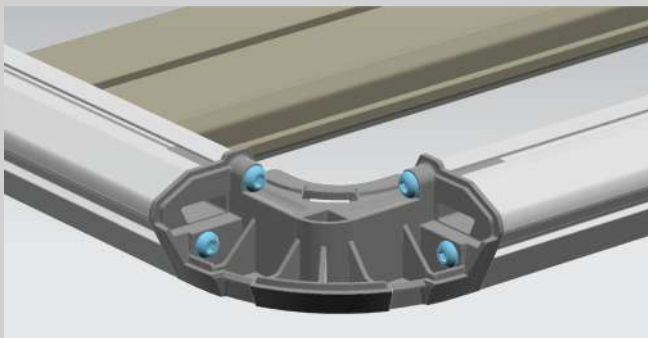



SIDE STEPS BRACKET KIT PRODUCT DEVELOPMENT

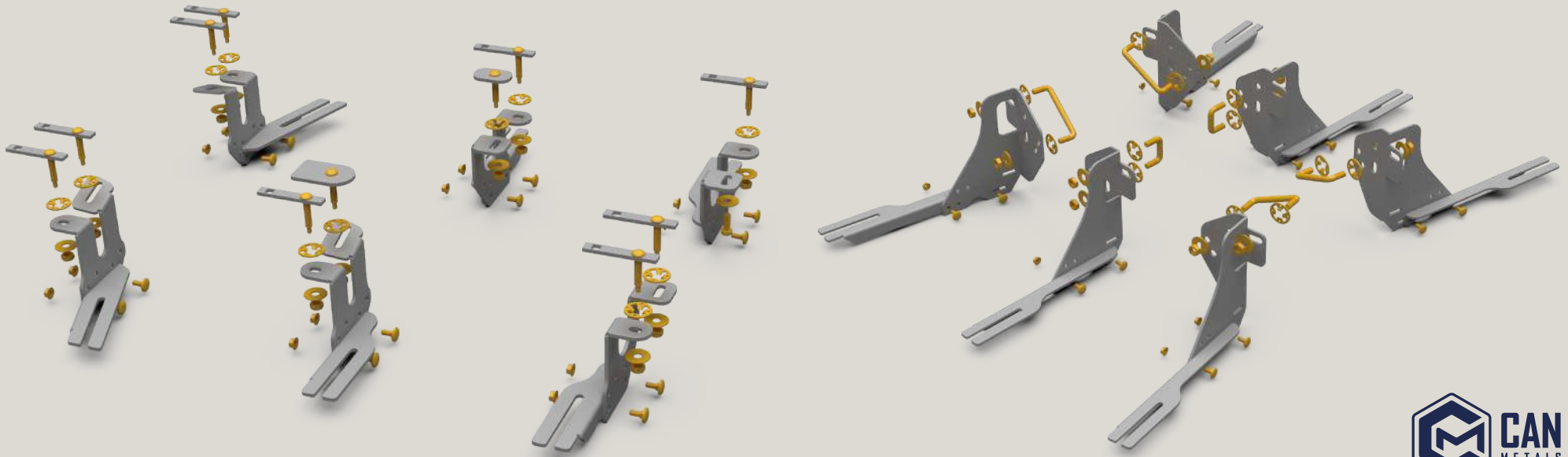



ROOFTOP **CANOE RACK** PRODUCT DEVELOPMENT

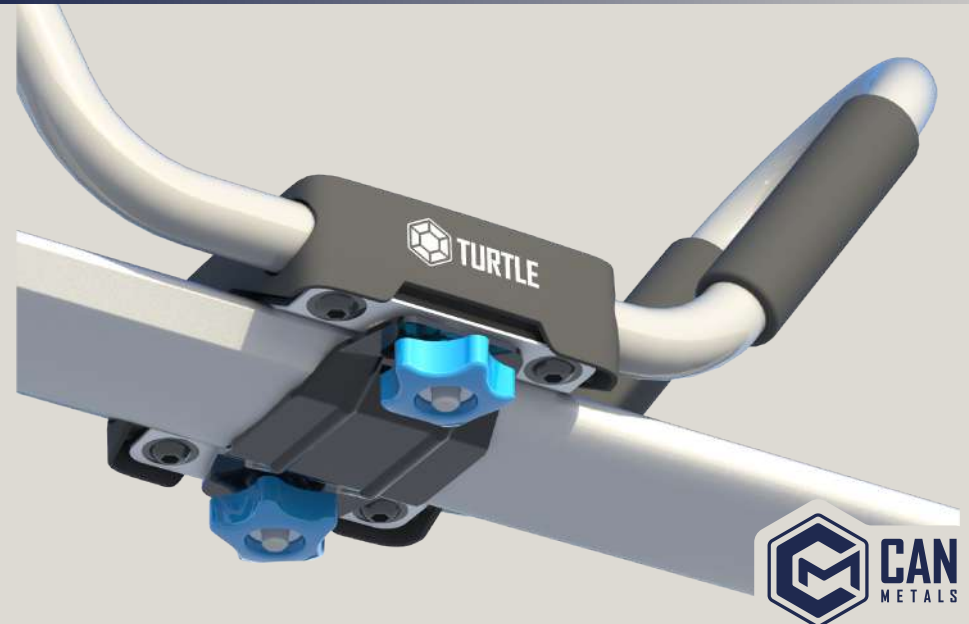
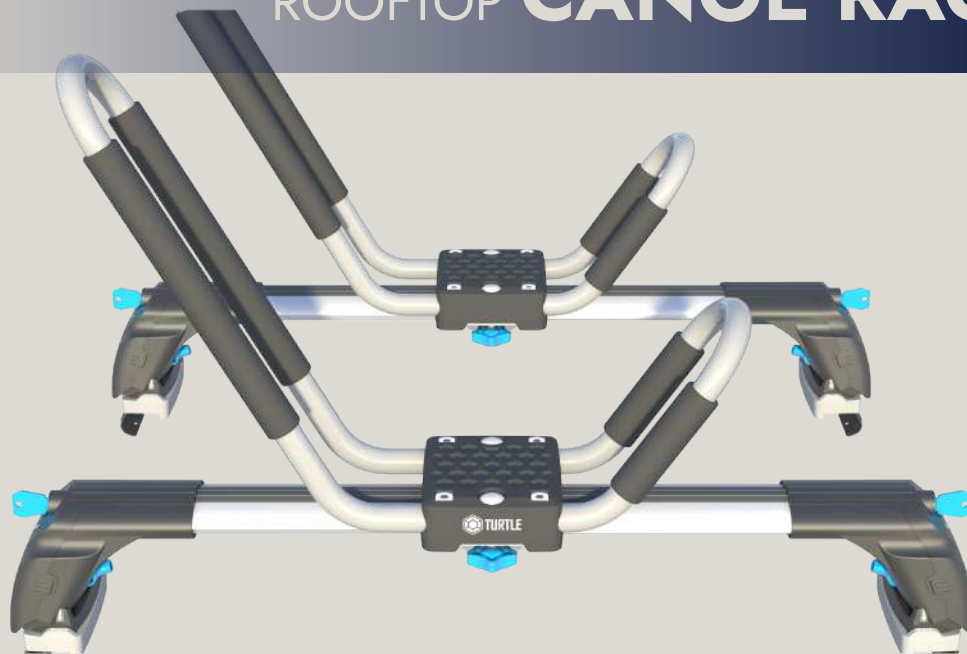

OUR MACHINE PARK

MOLD WORKSHOP

CNC MILLING | ELECTRICAL DISCHARGE MACHINING
MOLD ASSEMBLY & FITTING



HERMLE C400U 5-Axis CNC



QUASER MV204C
3-Axis CNC



QUASER MV184C
3-Axis CNC



HISION VMC1000
3-Axis CNC



AWEA AF-650II
3-Axis CNC



Foreman ARM40x10
Radial Drill



WDM ZQ3040x10/1
Radial Drill



OSCARMAX S430S
CNC EDM



ELAR ZNC-435Y
Plunge EDM



ELAR ZNC-325Y
Plunge EDM



FIRST LC 20 VHS
Molder Milling Machine



BILZ ISG3410WK-WS
Shrink

FROM OUR **MACHINING** PRODUCTIONS



FROM OUR **MACHINING** PRODUCTIONS



OUR MACHINE PARK

PLASTIC INJECTION PLASTIC INJECTION & PAD PRINTING AUTOMATIC PACKAGING



ARLEX AX-358 Servo Plastic Injection



HAITIAN MA4700II
Servo Plastic Injection



HAITIAN MA2500II
Servo Plastic Injection



HAITIAN MA2500
Servo Plastic Injection



TAIWAN KT-300-D(DM)
Plastic Vertical Injection



SML SSB-100
Raw Material Mixer



RHONG RG-2630
Powerful Plastic Crusher



SML SG-400F
High Speed Crusher



HAITIAN MA900II
Servo Plastic Injection



Inkprint EAZY 130 2C
2 Color Pad Printing



Inkprint EAZY 130 1C
Pad Printing



Inkprint EAZY 90
Pad Printing



TAMPO-MATIC TCCT 101
2 Color Pad Printing



GZE ZB-T60 D4
Automatic Bagging



FROM OUR **PLASTIC INJECTION** PRODUCTIONS



FROM OUR **PLASTIC INJECTION** PRODUCTIONS



FROM OUR **PLASTIC INJECTION** PRODUCTIONS



OUR MACHINE PARK

PRODUCTION METAL PROCESSING

FIBER LASER CUTTING (SHEET METAL & PROFILE)
SHEET METAL BENDING | ALUMINUM VERTICAL MACHINING

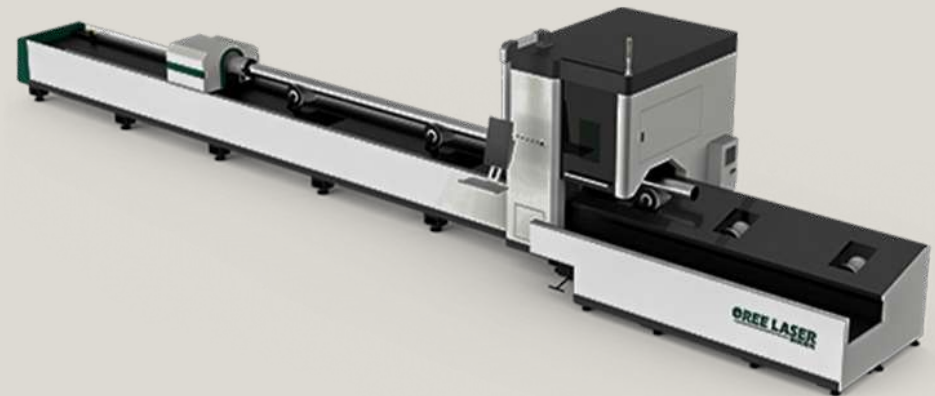

OREE OR-PH3015 3000 x 1500 MM 6KW FIBER LASER

OREE OR-TG6035 φ350 MM 1.5KW FIBER PROFILE LASER



EMMEGI Phantom M3
CNC Vertical Machining



STM STB-38CNC-4A-3S
Hybrid Pipe Bending



YLM MC-400VO-SA-HT
Circular Saw Cutting



COASTONE OY C-900
Servo-Electric PressBrake



OZGUR Makine
Pipe Forming Machine

OUR MACHINE PARK

PRODUCTION METAL WORKING

PRESS | SAW CUTTING | PROFILE BENDING
SCREWING | DRILLING | WELDING



Tesbihci 30 Ton
C Type Eccentric Press



Yesilyurt 80 Ton
C Type Eccentric Press



VOUGA JB04 - 1 Ton
Desktop Eccentric Press



YILMAZ KD 402S Saw Double Head Straight/Angle



OZCELIK METEOR I 420
Automatic Bottom Saw



YILMAZ ACK 420S
Bottom Out Saw



ARTIKON SD-201 Vertical
Automatic Screwdriver



AKYAPAK APK 30
Akbend Profile Bending



AKYAPAK APK 45
Akbend Profile Bending



Tamis TZ11/2K
Double Arm Belt Sander



Magmaweld Argon
TIG Welding



Oerlikon GKG 350
Gas Welding



EKCELIK 2DK-13
Table Top Drill



BOSCH PBD 40
Bench Type Drill

FROM OUR **MACHINING** PRODUCTIONS



FROM OUR **MACHINING** PRODUCTIONS

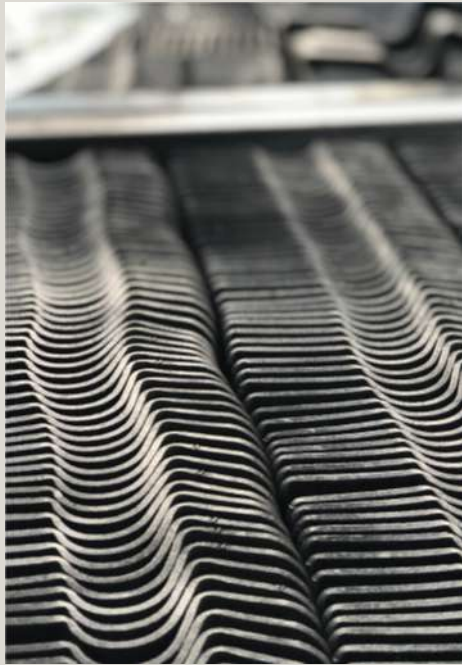

FROM OUR **MACHINING** PRODUCTIONS



3D SCAN & MEASUREMENT | REVERSE ENGINEERING



ARTEC LEO 3D Scanner Wireless AI-Powered



Faro Quantum ScanArm

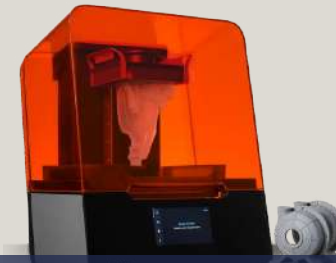

FORMLABS FORM 3+ Industrial SLA 3D Printer



FARO Quantum E V2 ScanArm Prizm LLP 3D Scanner

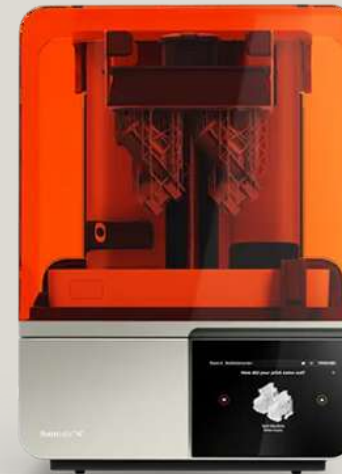

FORMLABS FORM 3+ Industrial SLA 3D Printer



3D PRINTING . **PROTOTYPE** . APPLICATION

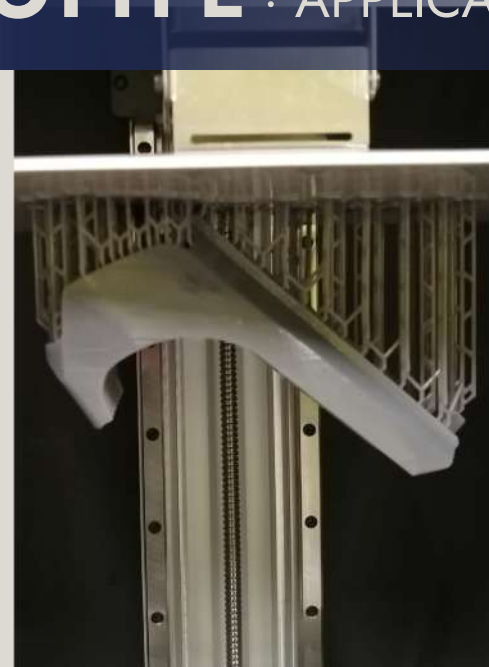

3D SCANNING & REVERSE ENGINEERING

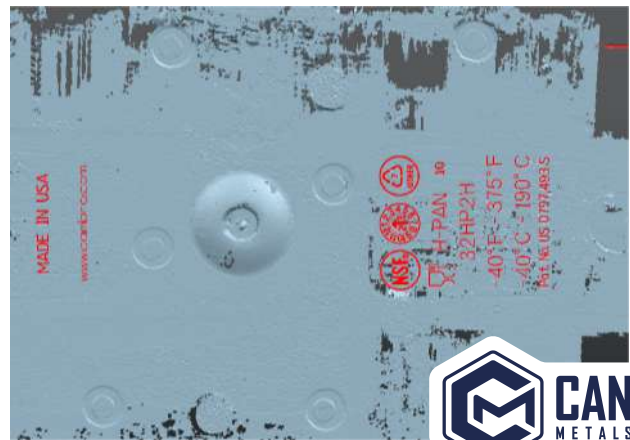
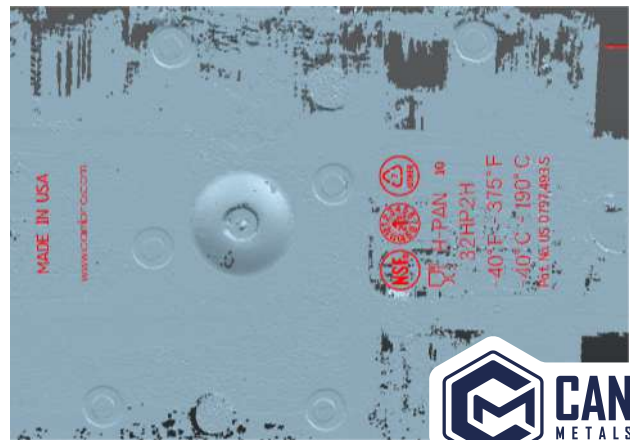
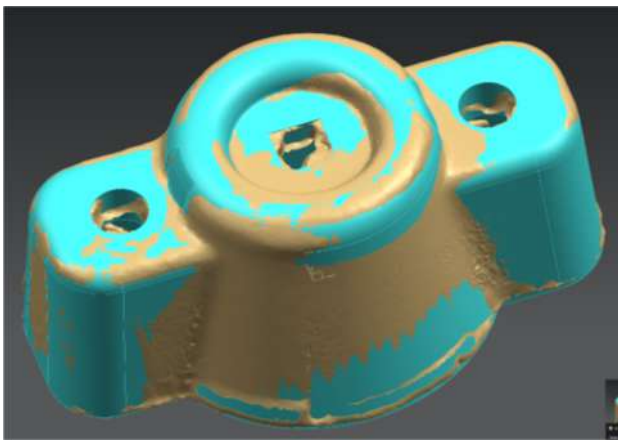
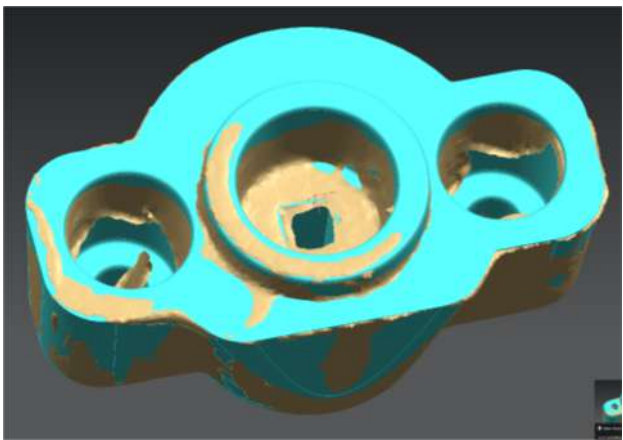
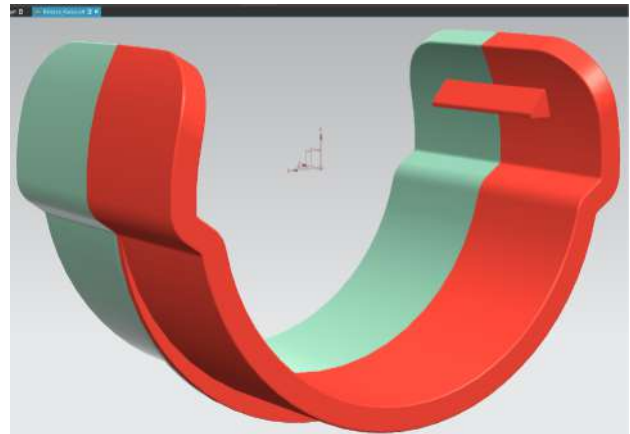
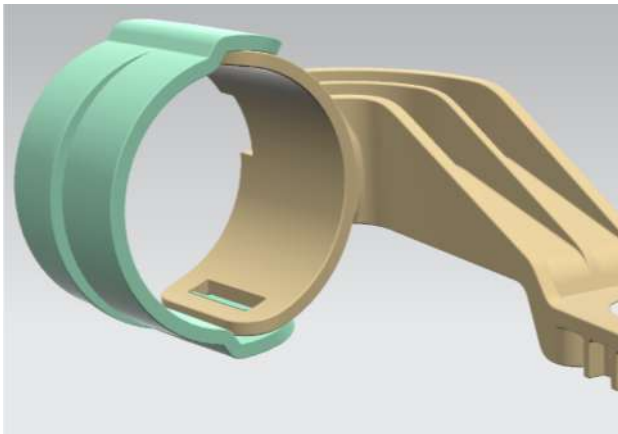
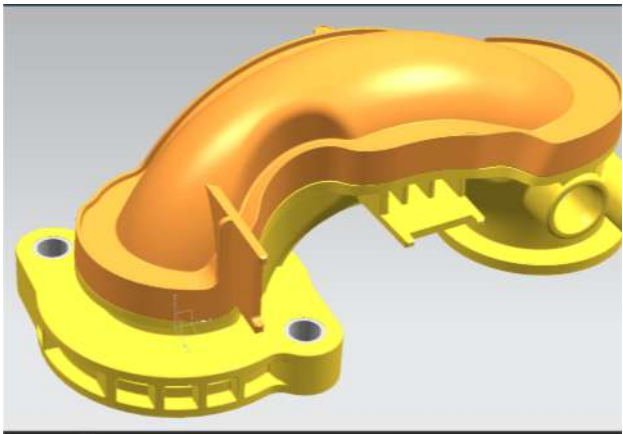
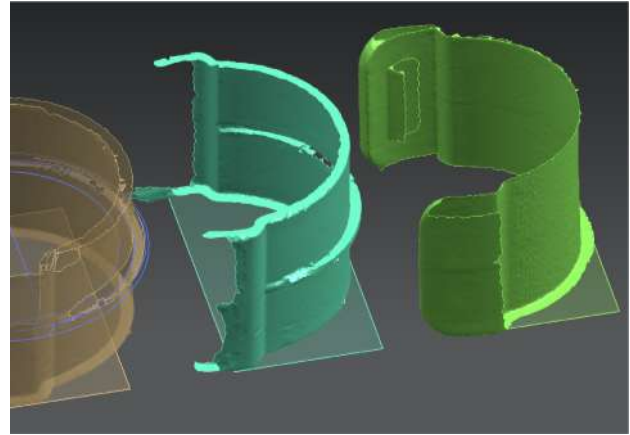
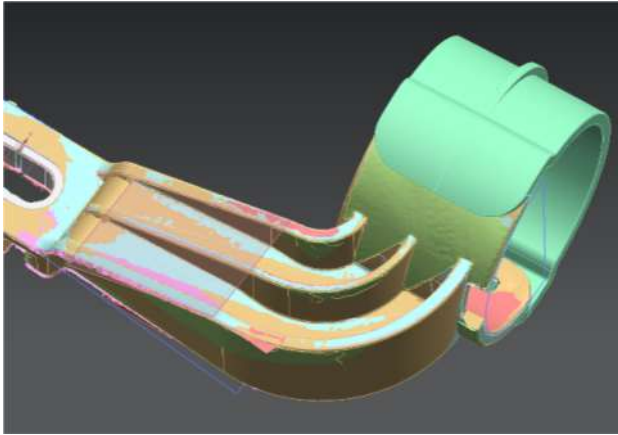
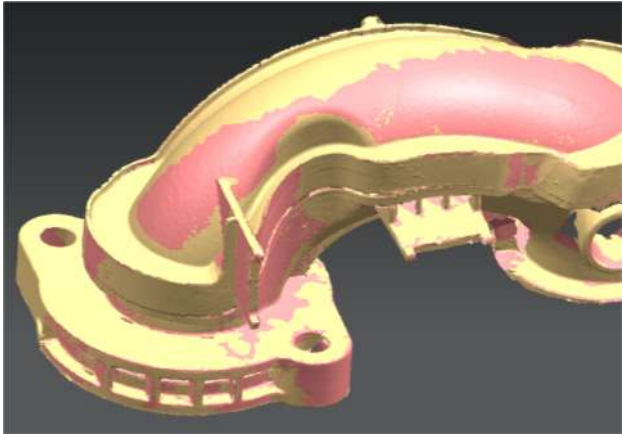

3D SCANNING & REVERSE ENGINEERING

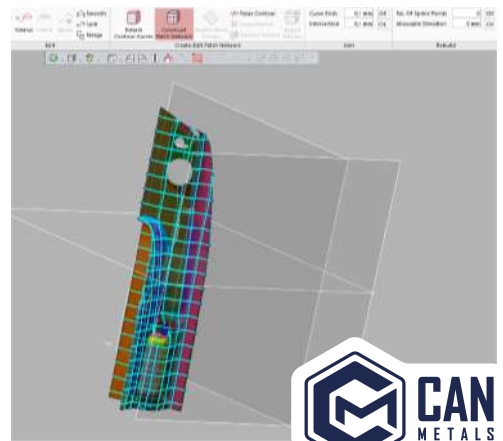
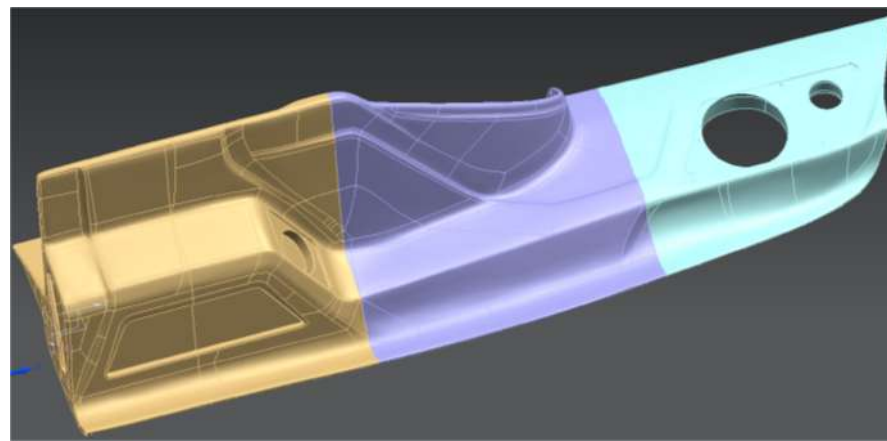
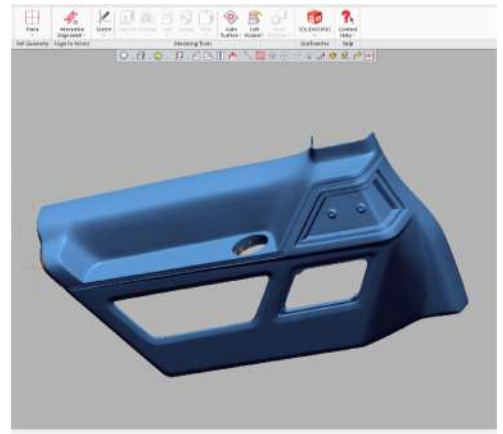
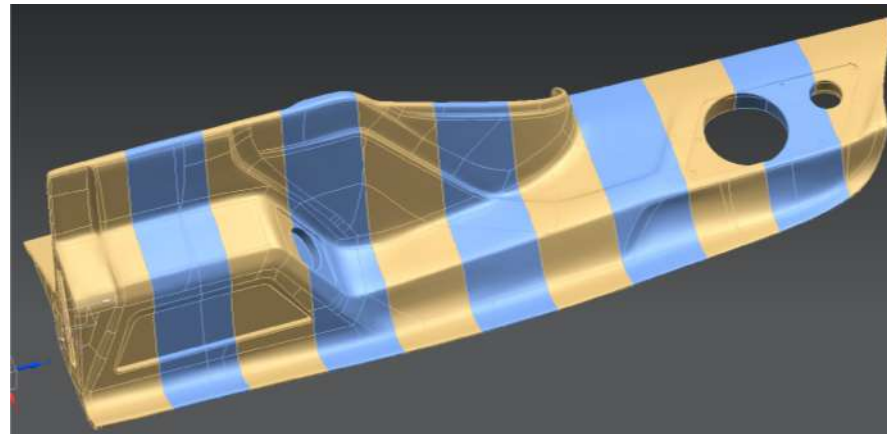
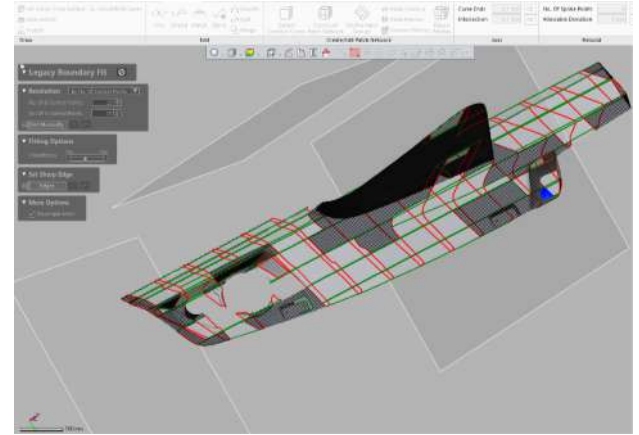
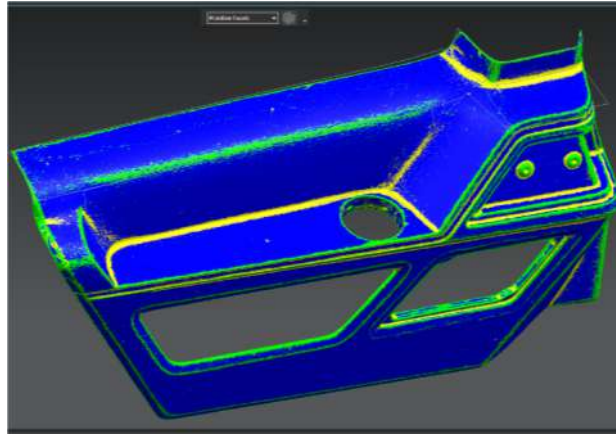
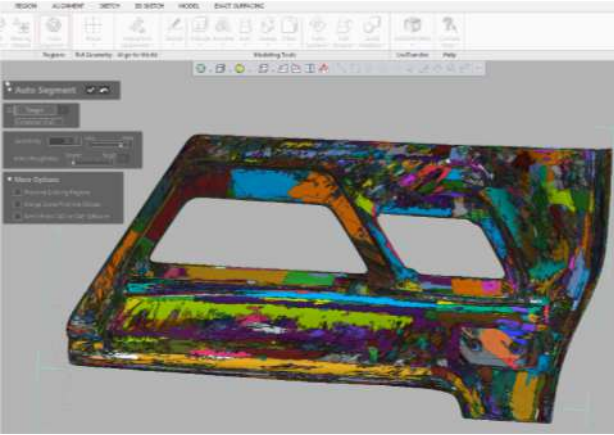

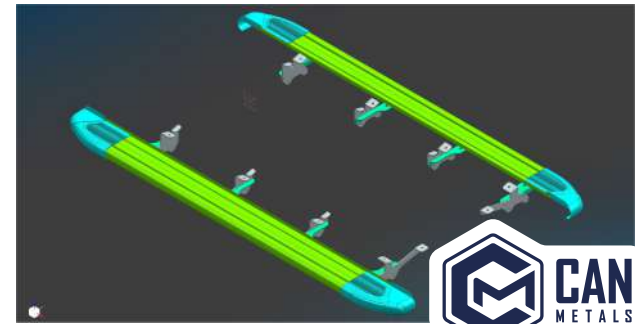
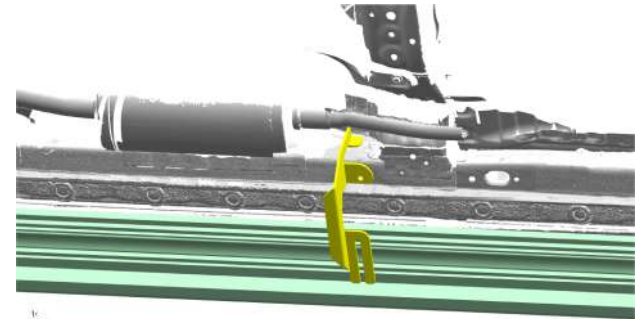
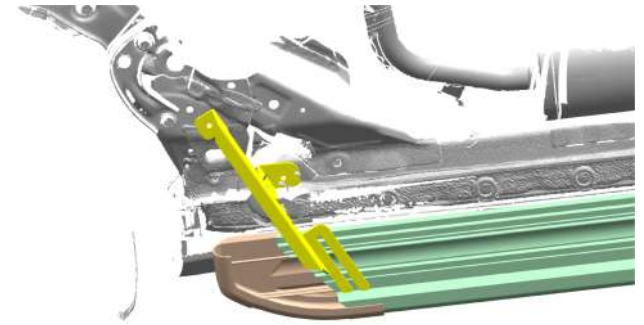
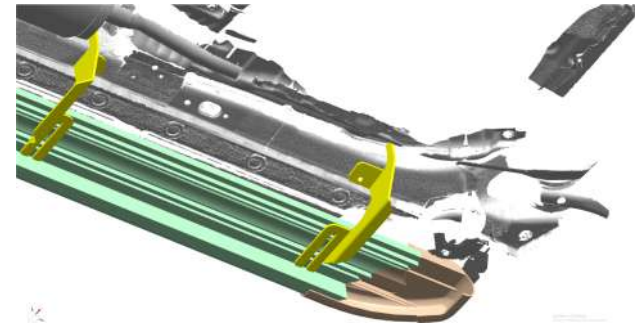
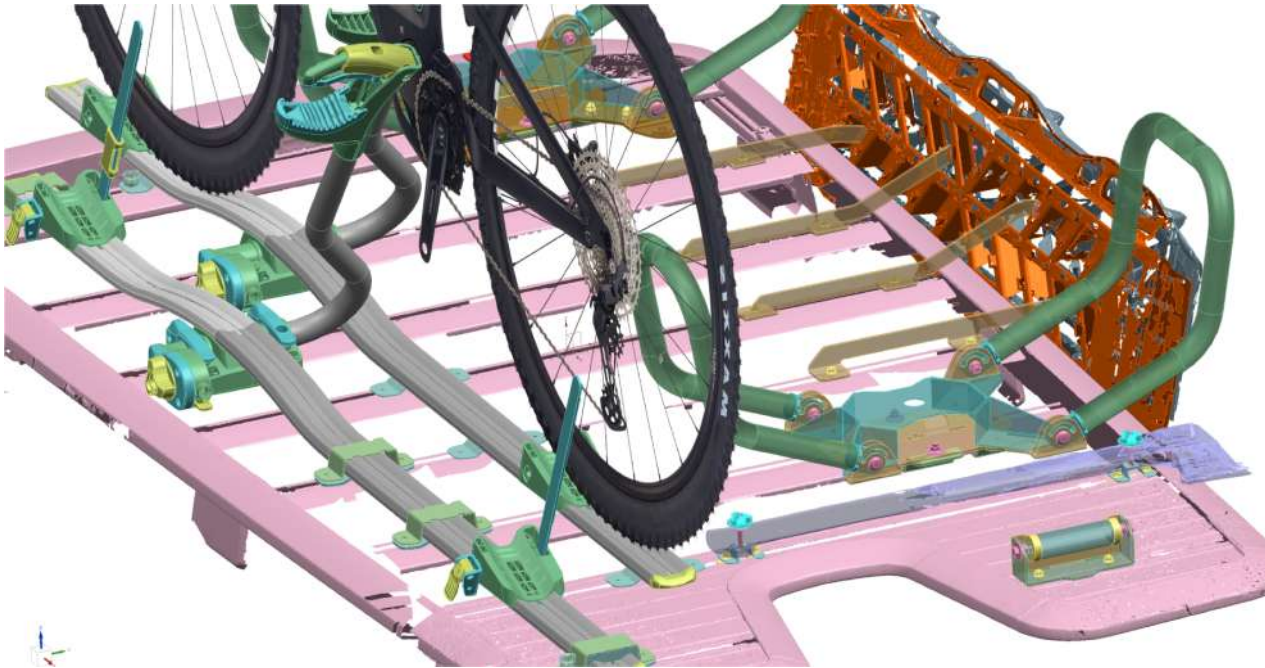
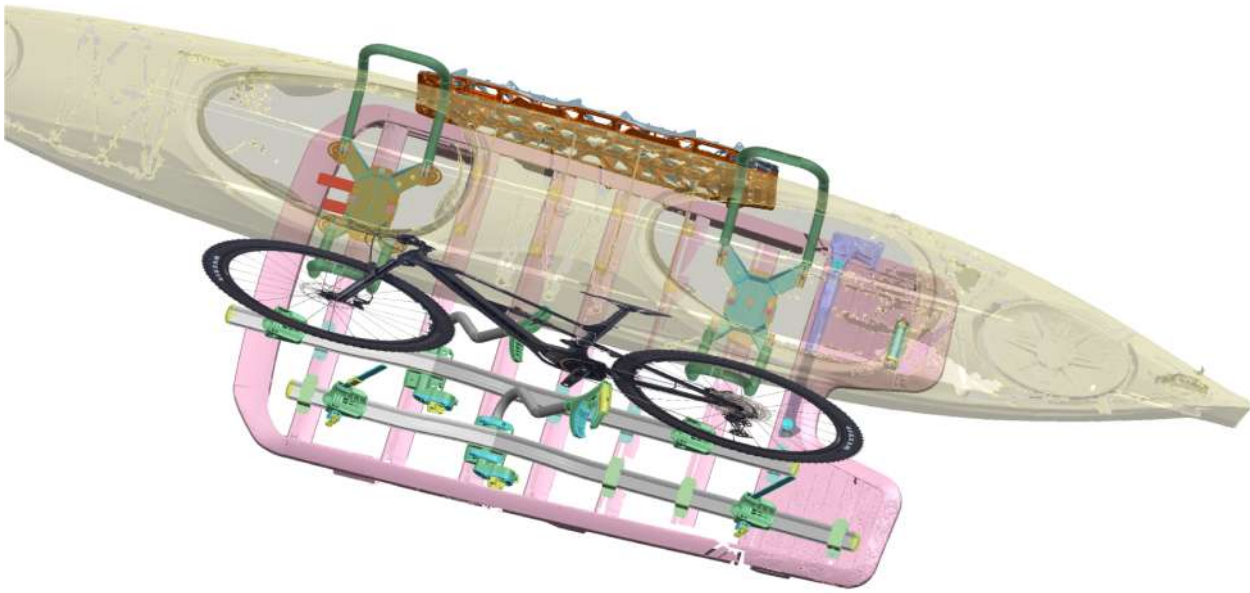

3D SCANNING & REVERSE ENGINEERING







CAN OTOMOTIV INS. ITH. IHR. SAN. VE TIC. LTD. STI.

 Velikoy O.S.B. 4. Cadde No:20/A
Cerkezkoy Tekirdag / Turkiye - TR

 info@canmetals.com

 **+90 530 155 26 66**
+90 282 746 13 20

 @canmetals

[canmetals.com](https://www.canmetals.com)

Preparer: Celalettin Toprak

